

NCE

The Power of DCC

Switch-It

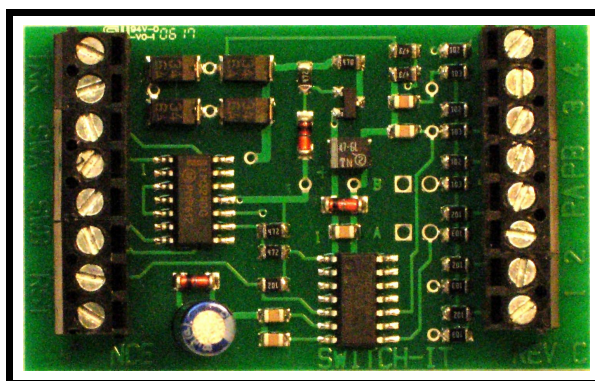

\$19.95

FOR STALL MOTOR SWITCH MACHINES ONLY
NOT FOR USE WITH TWIN COIL SWITCH MACHINES
Dimensions: 2.1" x 1.3" (54 x 33 mm)

This is an accessory (switch machine) decoder

- ✓ Control for two Tortoise™ switch machines
- ✓ Switch-It remembers the position of switch during power outages
- ✓ Switch-It supports the full range of DCC accessory addresses (1-2044)
- ✓ Easy address programming, no need to connect it to programming track
- ✓ Each switch machine can have its own completely different address
- ✓ Simple hook up, 2 wires to the track, 2 wires to each switch machine
- ✓ Includes optional connections for "local" control push buttons
- ✓ Also operates on non-DCC layouts



05240114

This book, schematics and artwork copyright 2009 NCE Corp., Webster, NY 14580

Warning: This product contains chemicals known to the state of California to cause cancer, birth defects or other reproductive harm.

Installation Notes:

This decoder is designed to control Tortoise, SwitchMaster or other low current "stall motor" switch machines. The outputs are rated for 50mA maximum. Most Tortoise machines draw 20 to 25mA with normal track voltage (about 13-15 volts). We use double sided foam tape to mount the Switch-It to the side of a Tortoise.

Wiring:

See the diagram below for wiring particulars. The only required wires are two wires to the track and two wires to each machine. It is OK to use the Switch-It for control of only one machine.

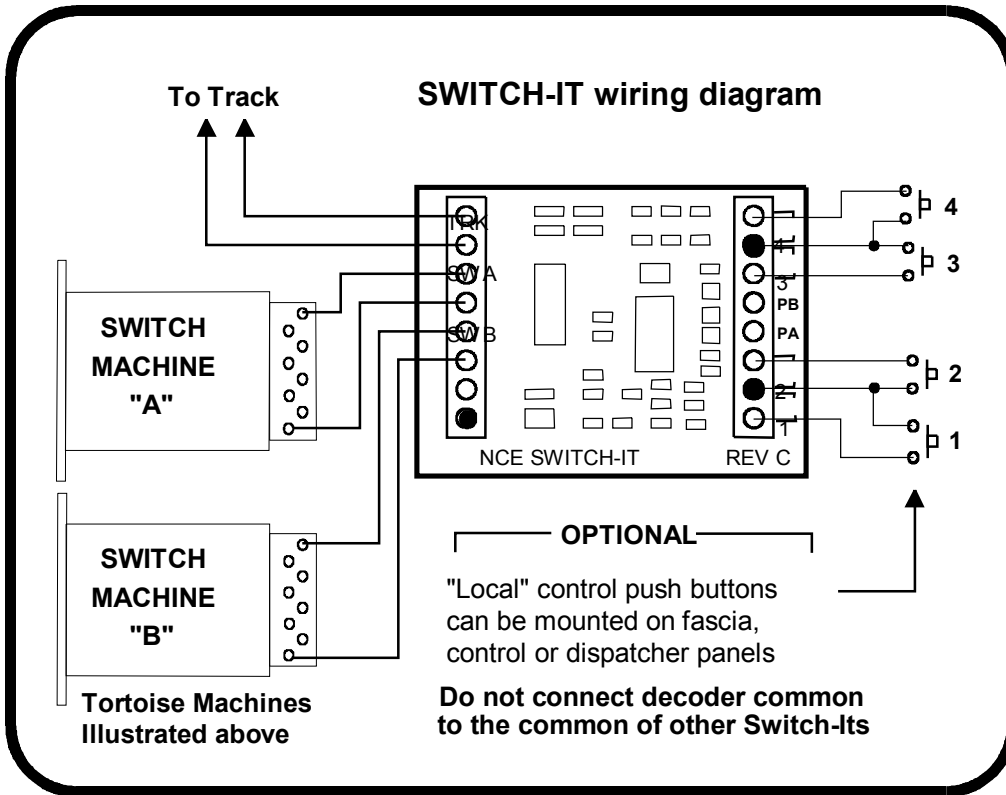

Optional push buttons:

Push buttons may be added for local control of the switches. Buttons 1 and 2 control switch "A" and buttons 3 and 4 control switch "B". Use momentary contact switches for local control. **Do not use a toggle switch** (unless it is momentary), its continuous connection will prevent DCC control of the turnout. In the illustration above the push button terminals filled in with black are "common" with each other. Buttons 1 and 2 are shown wired with a common wire to each push button as are buttons 3 and 4. It is OK to use only one common wire for all 4 push buttons. You can have multiple buttons wired in parallel for operation of the machine from more than one control panel. If the Switch-It is used on DC (12-16 volts DC) the buttons will still work. You can also program the Switch-It to "toggle" the outputs with each push of the local control pushbuttons. Button 1 will control the SWA output and button 4 will control the SWB output. Buttons 2 and 3 will be ignored and are not needed.

Switch machine mounting tip:

On our Tortoise machines we use hot glue to mount the machine. The glue stays liquid just long enough after application to allow alignment of the machine. We manually center the arm of the machine then slide the machine around while the glue sets to align the points to the middle of their throw. The low temperature hot glue is weak enough to allow removal of the machine later on by prying with a putty knife. Use a throw wire that is about 6" (150mm) longer than the one provided with the Tortoise to give you room to put glue on the machine after the wire is put through the roadbed.

Programming information

The Switch-It **cannot** be programmed on your programming track. It is always programmed while connected to the mainline track. This decoder can be programmed by all systems that support accessory control using the procedure below.

To program switch "A" to a new address using any DCC system:

- 1) Connect wires from the track to the decoder **TRK** connections.
- 2) Connect a short "jumper" wire from the **PA** terminal to common as shown below.
- 3) Use your DCC system to throw the accessory (switch) number you want the Switch-It to use as its **new** address.

To throw a switch using the NCE or MRC system:

Press "SEL ACCY"

Type in the accessory number followed by "ENTER"

Push "1" to throw the switch.

To throw a switch using a Digitrax system:

Press "SWCH"

Type in the accessory number

Push "OPTN" to throw the switch.

To throw a switch using a Lenz system:

Press "F"

Press "5"

Type in the accessory number followed by "ENTER"

Push "+"

- 4) Remove the jumper wire.

Do **not** leave the jumper in place after programming or you won't be able to control the switch.

To program switch "B" to a new address using any DCC system:

- 1) Connect wires from the track to the decoder **TRK** connections.
- 2) Connect a short "jumper" wire from the **PB** terminal to common as shown below.
- 3) Use your DCC system to control the accessory (switch) number you wish the decoder to use as its address for the **SWB** output. (see step 3 above)
- 4) Remove the jumper wire.

Do **not** leave the jumper in place after programming or you will not be able to control the switch.

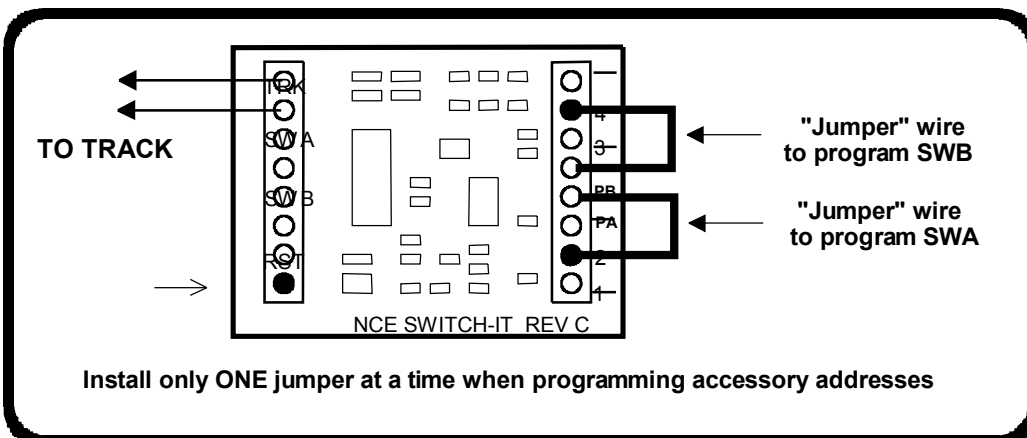

CV Programming:

The Switch-It generally uses Accessory OPs programming mode for its CVs. On the NCE Power Pro™, PowerCab™ and SB3 Accessory OPs programming is called "PROG ACCESSORIES". You can use this feature of your system to program CVs for the Switch-It.

If you have another brand of DCC system you can use loco OPs mode to program CVs with the following procedure:

- 1) Connect **PA** to common as shown above. While **PA** is connected in this manner the Switch-It will accept Loco OPs programming commands to its CVs as if they were Accessory OPs programming commands.
- 2) Use loco OPs programming to program CVs in the Switch-It. Make sure that you use a loco address that is NOT in use on your layout.
- 3) Remove the **PA** to **common** jumper when done programming.

Set pushbutton 1 to "toggle" the SWA output(disables pushbutton 2):

Set CV548 = 1 (use the accessory address of SWA) to enable the 'toggle' option or set CV548 = 0 to disable it.

Set pushbutton 4 to "toggle" the SWB output(disables pushbutton 3):

NCE Power Pro™ or PowerCab™ users can use the PROG ACCESSORIES feature of your system. Set CV549 = 1 (use the accessory address of SWB) to enable the 'toggle' option or set CV549 = 0 to disable it.

To set the Switch-It to "exercise" the switch points at each power up:

NCE Power Pro™ or PowerCab™ users can use the PROG ACCESSORIES feature of your system. Set CV547 = 1 (use the accessory address of SWA) to enable the 'exercise' option or set CV547 = 0 to disable it.

Legacy OPS programming disable (CV554):

There are two methods for programming accessory decoders "on the main" (OPS mode programming). Legacy mode, in use since 1995, is being phased out by the NMRA and replaced by the current, newer method. The Switch-It supports both kinds of programming on the main.

NCE Power Pro™ or PowerCab™ users can use the PROG ACCESSORIES feature of your system. Disable Legacy mode by setting CV554 to a value of 1. If you disable legacy mode and find you can no longer program the decoder with your system, your system only supports legacy mode. You can re-enable Legacy mode by resetting the Switch-It back to factory defaults as described below.

Pushbutton lockout (CV556):

On some layouts it may be desirable to disable operation of the local control pushbuttons. NCE Power Pro™ or PowerCab™ users can use the PROG ACCESSORIES feature of your system.

Set CV556 = 1 to disable the optional pushbutton inputs. CV556 = 0 enables the buttons.

You can disable or enable ALL decoders on the layout at the same time by using the accessory decoder broadcast address of 2044 when programming CV556.

Factory reset:

Momentarily connecting the two RST terminals will reset the decoder to the original factory settings as indicated below

Factory default values for decoder

- Output SWA is factory programmed to accessory address 1 (decoder addr 1, output 1)
- Output SWB is factory programmed to accessory address 2 (decoder addr 1, output 2)
- CV547 is set to 0 (Power up exercising of switch machine disabled)
- CV548 is set to 0 (use pushbutton 1 to "toggle" output SWA, pushbutton 2 is disabled)
- CV549 is set to 0 (use pushbutton 4 to "toggle" output SWB, pushbutton 3 is disabled)
- CV554 is set to 0 (legacy accessory OPS programming enabled)
- CV556 is set to 0 (pushbutton lockout is disabled)

Other technical stuff:

- We have successfully controlled two Tortoise switch machines with one decoder output when used in a crossover. We can't guarantee this will work in all cases.
- The outputs of the decoder are always on to prevent the switch machine from backing off due to the springiness of the turnout throw mechanism.
- If CV547 is programmed to 1 ("exercise" enabled) the decoder will "back off" the switch (usually about halfway) then return the switch to its remembered position at power up. This is to make sure the points are fully thrown (solves sticky point problems).
- See the diagram below for turnout position indicator light wiring. LEDs are wired in series with the switch machine to indicate which position the turnout is thrown. Most LEDs will handle up to 25mA, the switch motor acts as the current limiting device for the LEDs. We use red and green LEDs but any color will do. The switch machine will run a bit slower with LEDs installed due to about a 1.5 volt loss in the LED.

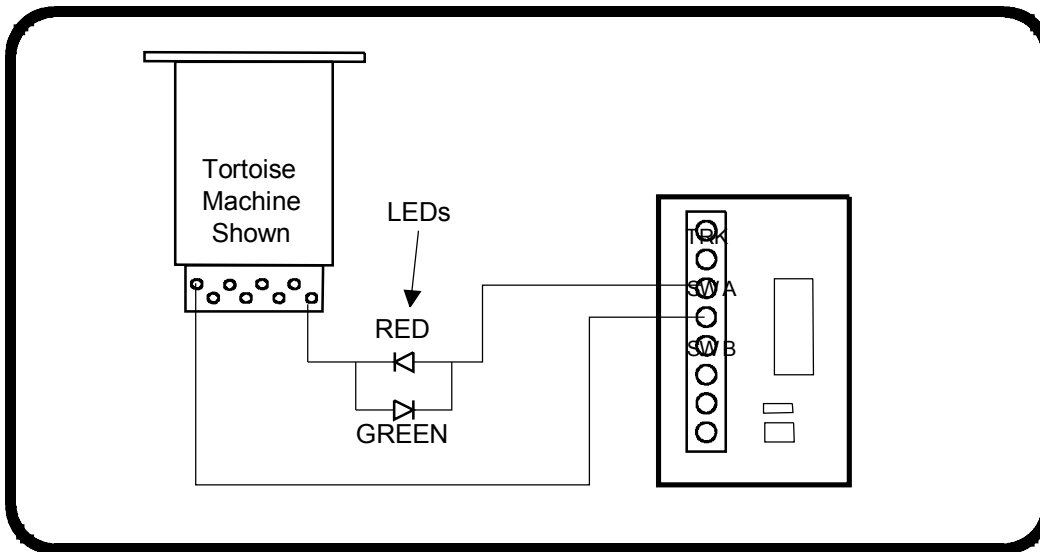

TIP:

If you use power routing turnouts such as Peco Electro-Frog, Shinohara or Walthers we suggest wiring a #1156 automotive taillight bulb in series with the points of the turnout (see above). This will prevent short circuits from shutting down your power booster in the event you enter the turnout from the frog end without aligning the points.

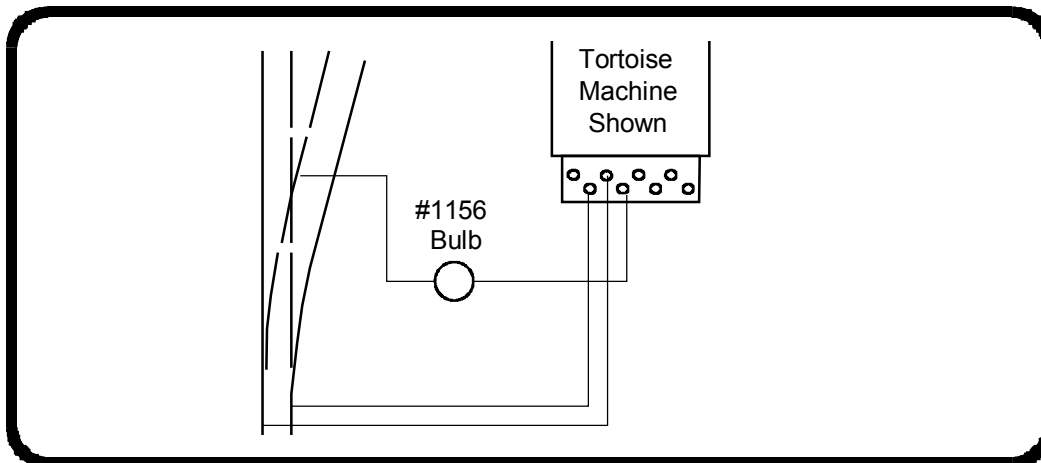

Warranty

This decoder is fully factory tested and warranted against manufacturing defects for a period of 1 year. As the circumstances under which this decoder is installed can not be controlled, failure of the decoder due to installation problems can not be warranted. This includes misuse, miswiring, operation under loads beyond the design range of the decoder or short circuits in the locomotive manufacturer's factory wiring. The warranty is voided if the decoder is miswired, connected to more than 22 volts, or used with switch motors drawing more than 40mA.

If the decoder fails for non-warranted reasons NCE will replace the decoder, no questions asked, for \$10 US plus \$2 shipping. For warranty or non-warranty replacement send the decoder (an any payment, if required) to:

NCE Warranty Center
82 Main Street
Webster, New York 14580



05240114

The terms Silent Running, Powerhouse Pro, Power Pro, ProCab, Power Cab, the NCE logo with "Power of DCC" slogan and the distinctive shape of the ProCab with thumbwheel and LCD are trademarks of NCE Corporation. Digitrax is a trademark of Digitrax Inc