



TEAM DIGITAL

SHD2

Dual Signal Head Decoder

Version 2

Improving the world of DCC

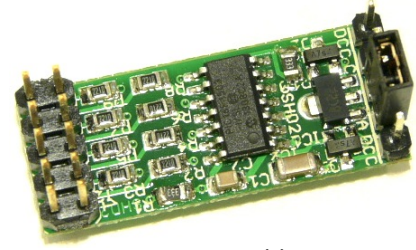

Features

- > DCC signal accessory decoder
- > Control 2 signal heads (4 aspects each)
- > Easy signal mast wire connections
- > Built-in resistors for LED drive
- > Prototypical lamp fade
- > Brightness adjustment
- > JMRI signal head compatible
- > RR&Co signal head compatible
- > Digitrax signal mast compatible

- > Included: SHD2, connector pins and heat shrink tubing

Description

The SHD2 is a DCC signal accessory decoder. It can control up to two signal heads with DCC Signal Head commands, compatible with JMRI Signal Heads, or standard DCC turnout (switch) commands. It can drive four individual LEDs (4 colors) per head. A total of eight outputs.

DCC Signal Head commands: Each head requires a unique address. A head can display up to nine aspects based on the aspect number. Since the SHD2 can control two heads it has two addresses. If a mast has only one head than the SHD2 can control two masts (1 head per mast). The SHD2 is pre-programmed with a DCC Signal address of 1 for head 1 and address 2 for head 2.

DCC turnout commands: Each head requires a unique address for each aspect. A head can display up to four aspects based on a turnout address. Since the SHD2 can control two heads it has four addresses in addition to close and throw. For the SHD2 to respond to turnout commands, a base turnout address must be programmed and Option 3 enabled.

For address change, brightness change and 3 lead bi-color see the Configuration Variable Table. Common anode or cathode LED signals are selected by the jumper position.

The SHD2 is controlled and powered by a DCC bus. Multiple SHD2s can be connected to the same bus.

When power is applied, lunar and green then yellow then red will light at full brightness. Then red will light at the brightness level set by the CV value. It will stay red until a different command is received.

DCC Signal Head addresses are a different type than turnout or locomotive decoder addresses. So a signal, turnout and loco decoder can each have the same address number without a problem.

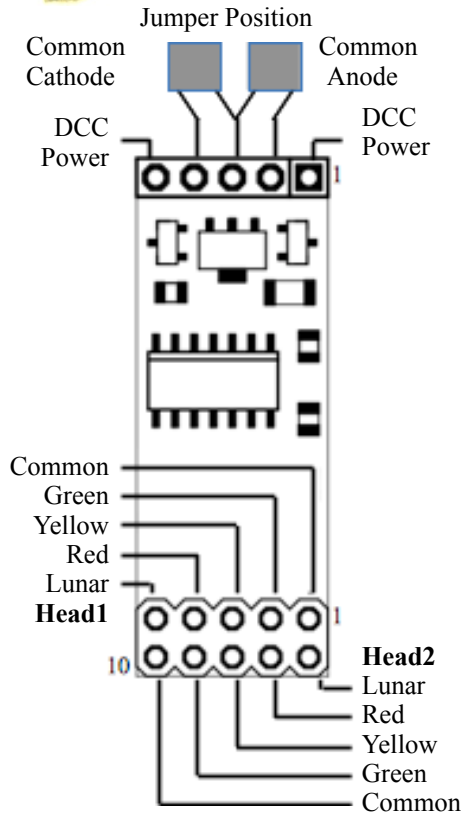
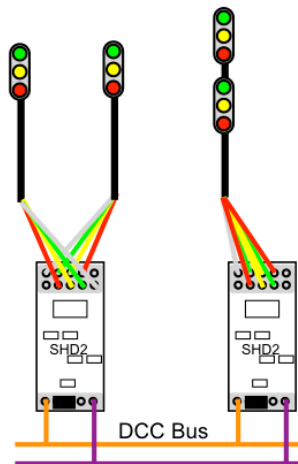

Aspect Number Table

This is the default definition for the JMRI 'DCC Signal Decoder'.

Red	0	Flash Red	4
Yellow	1	Flash Yellow	5
Green	2	Flash Green	6
Lunar*	3	Flash Lunar*	7
		Dark	8

Note: This table is also used for the alternate aspect number when turnout control is used.

*If Option 2 is enabled, the control of these aspects is disabled.

SHD2 Addresses

The address is made up of two CV values. An address CV and an address Adder CV. If an address greater than 255 is needed then use the address adder. The address adder value represents a number that is added to the address value to give the 'actual' address. The Address Adder table shows the CV value to use for the adder.

Example: for an address starting at 260, CV2 = 4 and CV3 = 1

To change the DCC Signal Head address, program CV2 (max value = 255) and CV3 (max value = 7) with the desired numbers. Head 1 will have the programmed address and head 2 will have the next higher address.

To change the turnout address, program CV5 (max value = 255) and CV6 (max value = 7) with the desired numbers.

Electrical Connections

Solder the female connectors to the mast wires. The long ears of the connector may have to be trimmed or bent so the tubing can slide over. Use the heat shrink tubing to cover the connector to avoid shorts when plugged in. When ready to install the mast, feed the connectors one at a time through the hole in the bench. Then push the connectors on the related SHD2 pins. With POWER OFF connect the two SHD2 Power pins to the DCC bus.

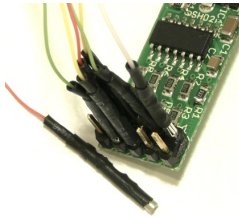

Turnout (Switch) Address for only Lunar outputs

When using DCC Signal head commands, if the lunar aspect is not required, those two outputs can be used to drive two LEDs using a turnout address independent of the other aspects. If a turnout address greater than zero is programmed for CV5 & 6, the lunar outputs can be used for turnout indication. This feature is disabled if Option 2 or Option 3 is enabled.

Configuration Variables (CVs)

The SHD2 supports **Paged Mode Programming in Service Mode**. To program in paged mode, connect the Power pins to the programming track. The SHD2 does not have built in feedback like a mobile decoder. Therefore, some systems may show a "no decoder on track" error or "can not read CV". However it still is programmed. If there is a LED connected to head 1 green output it will flash when a CV value is programmed. For CV read back, LEDs should be connected to head 1 and 2 RYG outputs. **Note:** may not work with all DCC systems.

Reset the SHD2 to factory setting: To "reset" the SHD2, program CV7 with a value of 170.

Note: The SHD2 is not compatible with incandescent lamps, LEDs with integrated resistors or 2-lead bi-color LEDs. Signals with LEDs wired in series may have a lower brightness.

Turnout Commands addr/aspect Table

Option 3 must be enabled. x represents the base turnout address.

Head 1 Example x = 1

Red	Addr x throw	1 t
Green	Addr x close	1 c
Yellow	Addr x+1 throw	2 t
Flash Yellow*	Addr x+1 close	2c

*Can be changed with CV18

Head 2

Red	Addr x+2 throw	3 t
Green	Addr x+2 close	3 c
Yellow	Addr x+3 throw	4 t
Flash Yellow*	Addr x+3 close	4 c

*Can be changed with CV19

Configuration Variables Table

CV#	Function	Default Value
1	N/U	-
2	Base Head Address	1
3	Base Head Address Adder	0
4	Reserved	-
5	Base Turnout Address	0
6	Base Turnout Address Adder	0

18	Alternate aspect number, head 1	5
19	Alternate aspect number, head 2	5
20	R1 Brightness Level, max 250	128
21	Y1 Brightness Level, max 250	128
22	G1 Brightness Level, max 250	128
23	L1 Brightness Level, max 250	128
24	R2 Brightness Level, max 250	128
25	Y2 Brightness Level, max 250	128
26	G2 Brightness Level, max 250	128
27	L2 Brightness Level, max 250	128
29	Decoder Configuration*	0

* For multiple options add the values together

Option 1: Value = 1 - 3-lead bi-color LED

Option 2: Value = 2 - Lunar on solid

Option 3: Value = 4 - Turnout commands control

option 3 does not disable DCC Signal commands

Address Adder

CV Value	0	1	2	3	4	5	6	7
Add	0	256	512	768	1024	1280	1536	1792

WARNING: This product contains a chemical known to the state of California to cause cancer, birth defects or other reproductive harm.