

The DBD22 can drive a relay with a low current coil. The relay shown has a coil current of 30 ma and a contact rating of 10 amps (Digikey PB380-ND). A clamping diode is required when driving a relay to suppress the voltage spike.

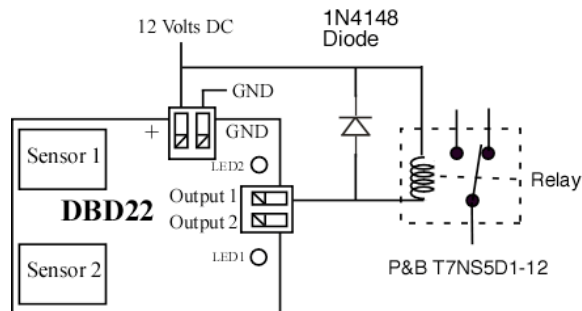

TEAM DIGITAL

Improving the world of DCC

DBD22 DCC Block Detector

- > Two detectors with LED indicators
- > Electrical isolation from the track
- > No track voltage drop
- > Low power requirements
- > Drive relays

Specifications:

Operating voltage: 5 to 15 volts DC

Typical operating current (unoccupied): 3 ma @ 5 volts, 8 ma @ 12 volts

Typical operating current (occupied): 8 ma @ 5 volts, 20 ma @ 12 volts

Maximum load per output: 150 ma

Typical trigger current: 3 ma* @ 5 volts, 6 ma @ 12 volts

Maximum continuous sensor current: 5 amps w/one pass of feeder wire

* To get 3 ma of track current ~ 4.7K ohms with 14 volts track or 3.9K ohms with 12 volts track are needed.

Warning

Do not reverse the ground and positive connections at the power connector or permanent damage will occur.

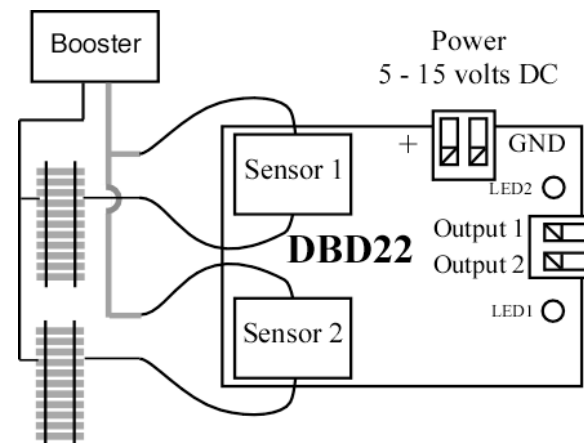

WARNING: This product contains a chemical known to the state of California to cause cancer, birth defects or other reproductive harm.

Operation:

The DBD22 is capable of sensing current in two isolated sections of track called blocks. This provides for detecting the presence of locomotives or other rolling stock that draw current from the track.

The track feeder wire for one rail of the block is passed through the hole in the sensor before connecting the feeder to the track. The track feeder wire sheathing should not be removed. When the current in the feeder going through the sensor reaches the trigger level, the output is turned on and the LED lights showing the block is occupied. Passing the feeder through the sensor more than one time will increase the sensitivity. However, this is NOT recommended because the maximum sensor current specification will be greatly reduced.

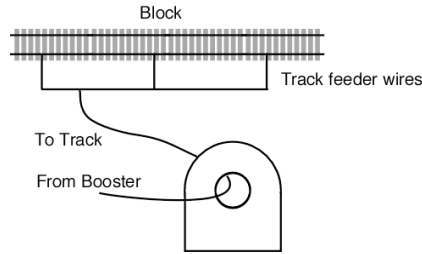

Locomotives and lighted cars draw enough current to trigger the DBD22. In order for other rolling stock to draw current, resistive wheel sets will have to be added. For HO scale (14 volts), one 4.7K ohm resistive wheel set will work per car. For N scale (12 volts), one 3.9K ohm resistive wheel set will work per car. If you want to use 10K resistive wheel sets you will need two or three wheel sets per car depending on track voltage. See specifications.

Dirty track can cause intermittent current flow. A built in filter keeps the DBD22 from rapidly turning off and on if the current flow is interrupted. Additionally, there is a small amount of hysteresis so that small changes in track current near the trigger point do not cause the DBD22 to turn off and on. The filter keeps the output on after a train leaves the block for a short period of time. This time is typically about 1 to 2 seconds. The amount of track current through the sensor has an effect on this time.

Since the DBD22 does not use diodes to sense track current there is no drop in track voltage. This allows you to “double sense” a block. For example, suppose you want to add a grade crossing with gates and flashers to a section of track that already has a diode sensing block detector. The block could be cut in to three smaller blocks to detect traffic on each approach and island blocks. DBD22s can be used for the three new blocks without interfering with the operation of the original detector or causing an additional track voltage drop. See the SIC24 signal and indicator controller for information on implementing a grade crossing.

Using the DBD22:

The Team Digital's SMD82, SIC24 and SRC8 all provide 5 volts and ground on each of their input connectors so they can directly power the DBD22. The following diagram shows an example of how to make the connections. Pins 1 and 2 are shown on the SIC24 input connector, but any of the inputs can be used.

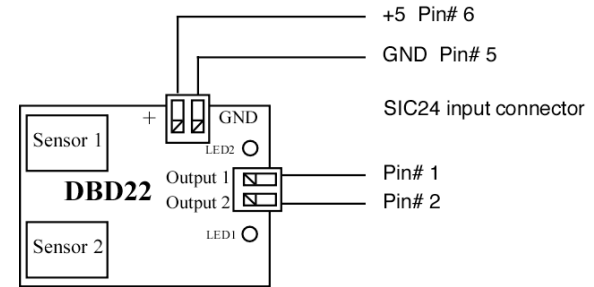

In some cases it may be desirable to use the DBD22 to just drive LEDs to indicate block occupancy. The following diagrams show how to connect a single color LED and a two lead bi-color LED. The power is shown as 12 Volts but could be 5 volts except for the case of the bi-color LED. In this case with the resistor divider, 5 volts is insufficient to light the LED. Notice that to drive a bi-color LED the auxiliary outputs are required. The normal outputs are an open collector type. This type output allows several DBD22 outputs to be ORed together. The auxiliary outputs are push pull type.

