

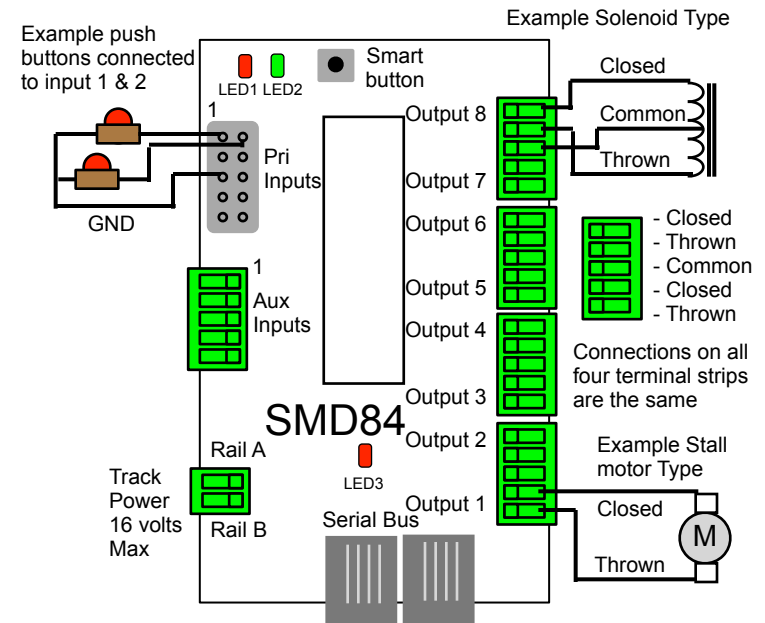

SMD84 Switch Machine Driver with Serial Bus

- > DCC compatible accessory decoder
- > Drives eight solenoid and/or stall type machines
- > Eight configurable routes
- > 13 Individually configurable inputs
- > Featuring “Smart” Programming
- > DCC gateway to serial bus
- > LocoNet[®] compatible serial bus

CV#	Function/Default Value		CV#	Function/Default Value	
173	Route 3 Cell 7 Address Adder	0	215	Route 6 Cell 4 Address Adder	0
174	Route 3 Cell 8 Address	0	216	Route 6 Cell 5 Address	0
175	Route 3 Cell 8 Address Adder	0	217	Route 6 Cell 5 Address Adder	0
176	Route 4 Cell 1 Address	0	218	Route 6 Cell 6 Address	0
177	Route 4 Cell 1 Address Adder	0	219	Route 6 Cell 6 Address Adder	0
178	Route 4 Cell 2 Address	0	220	Route 6 Cell 7 Address	0
179	Route 4 Cell 2 Address Adder	0	221	Route 6 Cell 7 Address Adder	0
180	Route 4 Cell 3 Address	0	222	Route 6 Cell 8 Address	0
181	Route 4 Cell 3 Address Adder	0	223	Route 6 Cell 8 Address Adder	0
182	Route 4 Cell 4 Address	0	224	Route 7 Cell 1 Address	0
183	Route 4 Cell 4 Address Adder	0	225	Route 7 Cell 1 Address Adder	0
184	Route 4 Cell 5 Address	0	226	Route 7 Cell 2 Address	0
185	Route 4 Cell 5 Address Adder	0	227	Route 7 Cell 2 Address Adder	0
186	Route 4 Cell 6 Address	0	228	Route 7 Cell 3 Address	0
187	Route 4 Cell 6 Address Adder	0	229	Route 7 Cell 3 Address Adder	0
188	Route 4 Cell 7 Address	0	230	Route 7 Cell 4 Address	0
189	Route 4 Cell 7 Address Adder	0	231	Route 7 Cell 4 Address Adder	0
190	Route 4 Cell 8 Address	0	232	Route 7 Cell 5 Address	0
191	Route 4 Cell 8 Address Adder	0	233	Route 7 Cell 5 Address Adder	0
192	Route 5 Cell 1 Address	0	234	Route 7 Cell 6 Address	0
193	Route 5 Cell 1 Address Adder	0	235	Route 7 Cell 6 Address Adder	0
194	Route 5 Cell 2 Address	0	236	Route 7 Cell 7 Address	0
195	Route 5 Cell 2 Address Adder	0	237	Route 7 Cell 7 Address Adder	0
196	Route 5 Cell 3 Address	0	238	Route 7 Cell 8 Address	0
197	Route 5 Cell 3 Address Adder	0	239	Route 7 Cell 8 Address Adder	0
198	Route 5 Cell 4 Address	0	240	Route 8 Cell 1 Address	0
199	Route 5 Cell 4 Address Adder	0	241	Route 8 Cell 1 Address Adder	0
200	Route 5 Cell 5 Address	0	242	Route 8 Cell 2 Address	0
201	Route 5 Cell 5 Address Adder	0	243	Route 8 Cell 2 Address Adder	0
202	Route 5 Cell 6 Address	0	244	Route 8 Cell 3 Address	0
203	Route 5 Cell 6 Address Adder	0	245	Route 8 Cell 3 Address Adder	0
204	Route 5 Cell 7 Address	0	246	Route 8 Cell 4 Address	0
205	Route 5 Cell 7 Address Adder	0	247	Route 8 Cell 4 Address Adder	0
206	Route 5 Cell 8 Address	0	248	Route 8 Cell 5 Address	0
207	Route 5 Cell 8 Address Adder	0	249	Route 8 Cell 5 Address Adder	0
208	Route 6 Cell 1 Address	0	250	Route 8 Cell 6 Address	0
209	Route 6 Cell 1 Address Adder	0	251	Route 8 Cell 6 Address Adder	0
210	Route 6 Cell 2 Address	0	252	Route 8 Cell 7 Address	0
211	Route 6 Cell 2 Address Adder	0	253	Route 8 Cell 7 Address Adder	0
212	Route 6 Cell 3 Address	0	254	Route 8 Cell 8 Address	0
213	Route 6 Cell 3 Address Adder	0	255	Route 8 Cell 8 Address Adder	0
214	Route 6 Cell 4 Address	0			



WARNING: This product contains a chemical known to the state of California to cause cancer, birth defects or other reproductive harm.



1 Introduction

The SMD84 is capable of driving eight solenoid (twin coil) and/or stall motor type switch machines. For solenoid type it contains a Capacitor Discharge Unit to store energy. A discharge of this energy is used to energize the solenoid to change the switch state. Using a CDU reduces the current drawn from the track to a small level sufficient to recharge the CDU. Once the CDU has been discharged (a switch state changed) a time period is required for the CDU to recharge. This is typically about three seconds. Since more than one switch may be requested to change state at the same time, as in a route, the requests are held or queued so that each switch may change state in turn. A stall motor type does not use the CDU and therefore, no recharge time is required when activated.

Caution: The CDU retains a voltage charge several minutes after power is removed.

Eight routes are supported. Routes can be executed from the throttle just like a single switch is or from buttons connected to inputs (local control). Each route has eight cells. There is one top or route execution address for each route. Each top address is completely independent of an SMD84 input or output address.

The SMD84 is an accessory decoder and can be controlled via DCC commands. It can also be controlled via the serial bus (LocoNet[®] compatible). For non-Digitrax users a DCC gateway feature allows DCC switch commands to be passed directly to the serial bus. This allows DCC switch commands to control devices connected to the serial bus.

LED 1 will light when the CDU is charging. During “Smart” programming it flashes to indicate the steps. A LED 2 flash indicates accepted program value. A LED 3 slow flash indicates heartbeat (fast flash indicates serial bus short).

2 Getting Started

The SMD84 comes from the factory ready to use. It is programmed to drive solenoid switch machines (three wire). An example of a three wire (twin coil) type switch machine is an Atlas Snap Switch[™] or a Peco. The eight outputs are programmed with addresses one to eight respectively. Connect the outputs of the SMD84 to the solenoid switch machines and RAIL A and RAIL B terminals to the track power as shown in the diagram on the front page. You are now ready to control your switches from the throttle.

You can control the outputs from fascia buttons by connecting them to the primary and aux inputs. The eight primary inputs, when grounded, will toggle the eight outputs respectively. The five aux inputs, when grounded, will throw the first five outputs respectively.

If you want to change the type of switch machine an output drives or some of the output addresses go on to “Smart” Programming section. If you want to customize the SMD84 go on to the Configuration Variables section.

2.1 Control via LocoNet[®] - Digitrax Users

The SMD84 comes from the factory ready to use by control from DCC commands. To control the SMD84 via LocoNet[®], it must be enabled. Connect the SMD84 track power terminals to the programming track and program CV29 with a value of 48. The SMD84 is now ready to be controlled via LocoNet[®]. The SMD84 should be connected to track power for proper CDU operation.

CV#	Function/Default Value		CV#	Function/Default Value	
87	Aux Input 2 Type & Address Adder	0	130	Route 1 Cell 2 Address	0
88	Aux Input 2 Transition	2	131	Route 1 Cell 2 Address Adder	0
89	Aux Input 3 Address	3	132	Route 1 Cell 3 Address	0
90	Aux Input 3 Type & Address Adder	0	133	Route 1 Cell 3 Address Adder	0
91	Aux Input 3 Transition	2	134	Route 1 Cell 4 Address	0
92	Aux Input 4 Address	4	135	Route 1 Cell 4 Address Adder	0
93	Aux Input 4 Type & Address Adder	0	136	Route 1 Cell 5 Address	0
94	Aux Input 4 Transition	2	137	Route 1 Cell 5 Address Adder	0
95	Aux Input 5 Address	5	138	Route 1 Cell 6 Address	0
96	Aux Input 5 Type & Address Adder	0	139	Route 1 Cell 6 Address Adder	0
97	Aux Input 5 Transition	2	140	Route 1 Cell 7 Address	0
98	Output Busy Timer	19	141	Route 1 Cell 7 Address Adder	0
99	Route SendDelay	0	142	Route 1 Cell 8 Address	0
100	Input Lockout Address	7	143	Route 1 Cell 8 Address Adder	0
101	Input Lockout Address Adder	0	144	Route 2 Cell 1 Address	0
102	reserved	-	145	Route 2 Cell 1 Address Adder	0
103	reserved	-	146	Route 2 Cell 2 Address	0
104	reserved	-	147	Route 2 Cell 2 Address Adder	0
105	reserved	-	148	Route 2 Cell 3 Address	0
106	reserved	-	149	Route 2 Cell 3 Address Adder	0
107	reserved	-	150	Route 2 Cell 4 Address	0
108	reserved	-	151	Route 2 Cell 4 Address Adder	0
109	reserved	-	152	Route 2 Cell 5 Address	0
110	reserved	-	153	Route 2 Cell 5 Address Adder	0
111	reserved	-	154	Route 2 Cell 6 Address	0
112	Route 1 Top Address	0	155	Route 2 Cell 6 Address Adder	0
113	Route 1 Top Address Adder	0	156	Route 2 Cell 7 Address	0
114	Route 2 Top Address	0	157	Route 2 Cell 7 Address Adder	0
115	Route 2 Top Address Adder	0	158	Route 2 Cell 8 Address	0
116	Route 3 Top Address	0	159	Route 2 Cell 8 Address Adder	0
117	Route 3 Top Address Adder	0	160	Route 3 Cell 1 Address	0
118	Route 4 Top Address	0	161	Route 3 Cell 1 Address Adder	0
119	Route 4 Top Address Adder	0	162	Route 3 Cell 2 Address	0
120	Route 5 Top Address	0	163	Route 3 Cell 2 Address Adder	0
121	Route 5 Top Address Adder	0	164	Route 3 Cell 3 Address	0
122	Route 6 Top Address	0	165	Route 3 Cell 3 Address Adder	0
123	Route 6 Top Address Adder	0	166	Route 3 Cell 4 Address	0
124	Route 7 Top Address	0	167	Route 3 Cell 4 Address Adder	0
125	Route 7 Top Address Adder	0	168	Route 3 Cell 5 Address	0
126	Route 8 Top Address	0	169	Route 3 Cell 5 Address Adder	0
127	Route 8 Top Address Adder	0	170	Route 3 Cell 6 Address	0
128	Route 1 Cell 1 Address	0	171	Route 3 Cell 6 Address Adder	0
129	Route 1 Cell 1 Address Adder	0	172	Route 3 Cell 7 Address	0

Summary of Configuration Variables

CV#	Function/Default Value	CV#	Function/Default Value
1	Output 1 Address	44	Pri Input 4 Address
2	Output On Time	45	Pri Input 4 Type & Address Adder
3	Output 1 Configuration	46	Pri Input 4 Transition
4	Output 2 Configuration	47	Pri Input 5 Address
5	Output 3 Configuration	48	Pri Input 5 Type & Address Adder
6	Output 4 Configuration	49	Pri Input 5 Transition
7	Manufacturer Version No.	50	Pri Input 6 Address
8	Manufacturer ID	51	Pri Input 6 Type & Address Adder
9	Output 1 Address Adder	52	Pri Input 6 Transition
10	Output 5 Configuration	53	Pri Input 7 Address
11	Output 6 Configuration	54	Pri Input 7 Type & Address Adder
12	Output 7 Configuration	55	Pri Input 7 Transition
13	Output 8 Configuration	56	Pri Input 8 Address
14	Output 2 Address	57	Pri Input 8 Type & Address Adder
15	Output 2 Address Adder	58	Pri Input 8 Transition
16	Output 3 Address	59	Sec Input 1 Address
17	Output 3 Address Adder	60	Sec Input 1 Type & Address Adder
18	Output 4 Address	61	Sec Input 1 Transition
19	Output 4 Address Adder	62	Sec Input 2 Address
20	Output 5 Address	63	Sec Input 2 Type & Address Adder
21	Output 5 Address Adder	64	Sec Input 2 Transition
22	Output 6 Address	65	Sec Input 3 Address
23	Output 6 Address Adder	66	Sec Input 3 Type & Address Adder
24	Output 7 Address	67	Sec Input 3 Transition
25	Output 7 Address Adder	68	Sec Input 4 Address
26	Output 8 Address	69	Sec Input 4 Type & Address Adder
27	Output 8 Address Adder	70	Sec Input 4 Transition
28	Status Report	71	Sec Input 5 Address
29	Decoder Configuration	72	Sec Input 5 Type & Address Adder
30	reserved	73	Sec Input 5 Transition
31	Ops Mode Address	74	Sec Input 6 Address
32	reserved	75	Sec Input 6 Type & Address Adder
33	Pwr On State - Outputs 1-4	76	Sec Input 6 Transition
34	Pwr On State - Outputs 5-8	77	Sec Input 7 Address
35	Pri Input 1 Address	78	Sec Input 7 Type & Address Adder
36	Pri Input 1 Type & Address Adder	79	Sec Input 7 Transition
37	Pri Input 1 Transition	80	Sec Input 8 Address
38	Pri Input 2 Address	81	Sec Input 8 Type & Address Adder
39	Pri Input 2 Type & Address Adder	82	Sec Input 8 Transition
40	Pri Input 2 Transition	83	Aux Input 1 Address
41	Pri Input 3 Address	84	Aux Input 1 Type & Address Adder
42	Pri Input 3 Type & Address Adder	85	Aux Input 1 Transition
43	Pri Input 3 Transition	86	Aux Input 2 Address

3 “Smart” Programming

“Smart” programming is a term used to describe an easy way to program Configuration Variables (CVs). The throttle is used to issue switch or accessory commands just like controlling switches (turnouts). The serial bus (LocoNet® in a Digitrax system) is not used.

There are three sections to “Smart” programming. You can start from any section. LED 1 (red) will flash indicating the step number. At any time you can exit “Smart” mode by pressing the button for approximately one second until LED 1 (red) stops flashing.

To start programming, connect the SMD84 power terminals to track power. Turn on power and wait until LED 1 (red) turns off. Press and hold the Smart button until you reach the desired section as show in the table below.

In section 1 of this table, all the output addresses and output configurations (solenoid type or stall type) are programmed. Use the throttle to select the switch address or accessory number you want for the beginning address of eight sequential addresses. Issue either a close or throw command for solenoid type or stall type. Input addresses are unchanged.

In section 2 of this table, individual output addresses and output configurations (solenoid type or stall type) are programmed. As you progress through the “Smart” programming steps, the red LED flashes the number of times indicating which step in the section is ready to be programmed. The green LED will flash briefly when programmed.

In section 3 of this table, CVs and input primary addresses are programmed. See section 4 to determine what values to use. If an input is to control an output it must be switch type and have the same address as the output.

See examples of “Smart” programming in section 6.1.

Smart Programming Summary			
# Flashes	Description	t	c
<i>Section 1: To start - Press the “Smart” button until the red LED starts to flash</i>			
1	Beginning address for 8 sequential output addresses	stall motor	solenoid
<i>Section 2: To start here - Press the “Smart” button until the green LED lights - Non-sequential addresses</i>			
1	Output 1 address	stall motor	solenoid
2	Output 2 address	stall motor	solenoid
3	Output 3 address	stall motor	solenoid
4	Output 4 address	stall motor	solenoid
5	Output 5 address	stall motor	solenoid
6	Output 6 address	stall motor	solenoid
7	Output 7 address	stall motor	solenoid
8	Output 8 address	stall motor	solenoid
<i>Section 3: To start here - Press the “Smart” button until the green LED lights and then turns off</i>			
1	Value of CV29 - Decoder configuration	set	clear
2	Value of CV28 - Status report	set	clear
3	Beginning address for 8 sequential primary input addresses	sensor type	switch type

Note: To use an accessory decoder to control switches (turnouts) an address and a switch state are required. The address is typically the number assigned to a switch. DCC manufacturers use different terminology for switch state. See table.

Switch (Turnout) Terminology		
This manual	throw or t	close or c
Digitrax	throw or t	close or c
NCE	reverse or OFF or 2	normal or ON or 1
Lenz	-	+
MRC	OFF	ON

4 Configuration Variables (CVs)

The SMD84 supports **Paged Mode Programming in Service Mode and Ops Mode**. To program in paged mode, connect terminals Rail A and Rail B to the programming track. See diagram below. When power is applied, LED 1 will come on and LED 2 will flash when programming is successful. Some systems only apply power during actual programming, so LED1 will only be on during that time. The SMD84 does not have built in feedback like a mobile decoder. Because of this, some systems may show a “no decoder on track” error or “can not read CV”. However it still is programmed. To enter normal operation, disconnect from the program track. Now connect terminals Rail A & B to the main track power.

To program in ops mode (On the Main Programming) connect terminals Rail A and Rail B to track power. Hold down the Smart button just before power is turned on. When the green LED turns on release the button then wait until the red LED turns off. The SMD84 is now in ops mode until power is turned off. The default ops address is one (1). **This is a loco address, so be careful when using this feature.** The SMD84 can be programmed so it is always in ops mode by setting option 3 in CV29. **When using ops mode to change CV values, the SMD84 does not recognize some new values until power is turned off and then back on.** Programming CV7 with a value of 1 will restart the SMD84 so power need not be cycled when programming in ops mode. This is the same as turning power off and then back on.

The SMD84 can be programmed in ops mode via the serial bus if it is enabled. CV values can be written and read. In a Digitrax system the SMD84 should be powered from a DC power supply when programming via Loconet.

Reset the SMD84 to factory defaults.

To “reset” the SMD84 to factory defaults, turn power on and wait until the LED turns off. Then press the “Smart” button and continue to hold the button down (at least 16 seconds) until both LEDs are alternately flashing.

Alternately, programming CV7 with 170 will “reset” all CV’s to the factory default value. In page mode this may not work with some systems as they do not keep power applied to the programming track long enough for all the CVs to be programmed.

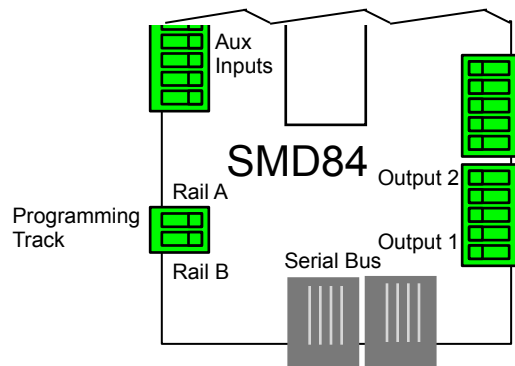

6.2 Other Input Devices

Typically you may connect push buttons to the SMD84 inputs as shown. The primary input connector provides a 5 volt source, so DBD22s (block detectors) can be powered and when connected to an input a route or turnout can be controlled.

6.3 Driving Other Devices

The SMD84 can be used to turn on devices other than switch machines. In some cases external auxiliary power is required. If the load is an inductance, a diode is required to suppress the positive voltage transient when the load is turned off. The diagram shows a LED, a lamp and an inductive load. Connect the minus or ground of the isolated external supply to GND.

An example of an inductance load is the Kadee electric uncoupler #307. This particular device can not have power applied to it very long or it may be damaged. To handle this set the SMD84 output configuration CV of the output connected to the uncoupler to a value of two (2). The default ‘on time’ is about eight seconds which is enough time to uncouple a car.

The connection TKDC provides DC from the track voltage and can be used for small current loads like LEDs. Maximum current is 500ma.

Use a small iron (20W-40W) for soldering to the board.

Note: The common connection is intended only to provide power to solenoid type switch machines (twin coil). Other uses will result in improper operation.

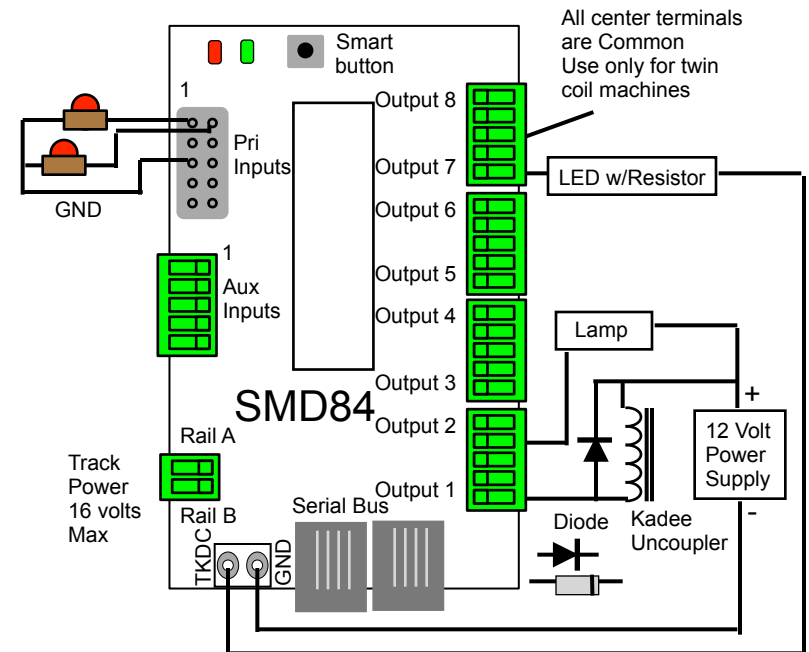

6 Applications

6.1 Examples of “Smart” programming

Example to set the SMD84 addresses from 9 to 16 for solenoid machines. See section 1 of the table in section 3.

Power on the SMD84 with track power, after 6 or 7 seconds hold down the Smart button until LED1 (red) is flashing. Using the throttle in switch mode issue the first address (9) with a close. LED 2 (green) will flash briefly. The SMD84 will restart indicated by LED 1 (red) on solid for several seconds. Inputs are unchanged.

Example to set the SMD84 addresses from 9 to 12 for solenoid machines and addresses 31 to 34 for Tortoise® machines. See section 2 of the table in section 3.

Power on the SMD84 with track power, after 6 or 7 seconds hold down the Smart button until LED1 (red) is flashing and LED 2 (green) is on solid. Using the throttle in switch mode issue the first address (9) with a close (solenoid). LED 2 (green) will flash briefly and LED1 (red) will now be flashing a two (step 2, two quick flashes with a pause then repeat). Using the throttle in switch mode issue the second address (10) with a close. Again LED 2 (green) will flash briefly. Continue this process for the next 2 steps until step 5 is reached. Here issue the fifth address (31) with a throw (Tortoise®). Continue until all steps are complete. At this point the SMD84 will restart indicated by LED 1 (red) on solid for several seconds.

6.2 Routes

The SMD84 is well suited to handle routes in a yard. The following shows an example of five routes using four turnouts. The route CV values were determined using the information in sections 4.6 and 4.7. One very nice tool that makes custom programming much easier is JMRI DecoderPro.

A route can be executed with an actual turnout (switch) address or a pseudo address of a turnout (not a physical turnout). Program the top address of the route with the address you want to execute the route.

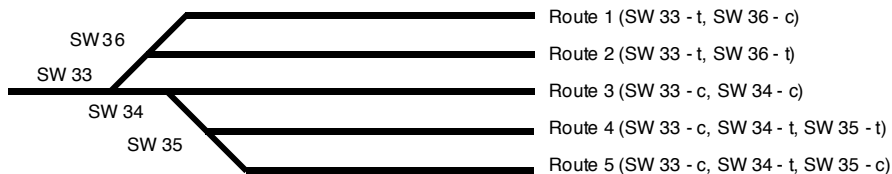

Yard diagram

Route Example								
Route	1	2	3	4	5	6	7	8
Execute address	101 t	101 c	102 t	102 c	103 t			
Address 1	33 t	33 t	33 c	33 c	33 c			
Address 2	36 c	36 t	34 c	34 t	34 t			
Address 3				35 t	35 c			
Address 4								
Address 5								
Address 6								
Address 7								
Address 8								

4.1 Output Address

These CVs determine the address of the outputs. Each output address is constructed of two CVs, an address and an address adder. See section 7 for CV numbers. If an address greater than 255 is needed then the address adder value will be greater than zero. Otherwise the address is set by the address value only. The address adder value represents a number that is added to the address value to give the required address. The Address Adder table shows the CV value to use for the adder. For easier programming see “Smart” Programming.

Address, a value from 0 to 255, Address adder, a value from 0 to 7

Note: Some systems refer to CV1 as AD, AD2 or short address.

Examples for Output 1					
Required address	34	220	266	524	898
Address CV1 value	34	220	10	12	130
Address Adder CV9 value	0	0	1	2	3

Address Adder								
CV value	0	1	2	3	4	5	6	7
Add	0	256	512	768	1024	1280	1536	1792

4.2 Output Configuration

CV3, 4, 5, 6, 10, 11, 12, 13- Output configuration

These CVs determine the output type.

Set the CV value to zero (“0”) for solenoid (twin coil) type operation.

Set the CV value to one (“1”) for stall motor (continually on) type operation.

Set the CV value to two (“2”) for 8 second motor on type operation (not queued). If the motor doesn’t have to be continually powered, use this type to reduce track current draw. The length can be adjusted by changing the value of CV2.

Set the CV value to four (“4”) for on/off independent control of both close and throw sides of an output.

4.3 Power On Output State

CV33 - Power on state for outputs 1 to 4, a value from 1 to 170

CV34 - Power on state for outputs 5 to 8, a value from 1 to 170

These CVs determine the state of each output at power on. Decoder configuration option 1 or option 2 has to be enabled for these CVs to function. You only need to program these CVs if option 2 is enabled. If option 1 is enabled, the SMD84 automatically programs them.

If neither throw or closed is selected the output does nothing. If both are selected this feature will not work correctly

Outputs 1 to 4	Value	Select
Output 1 throw	1	1
Output 1 close	2	
Output 2 throw	4	4
Output 2 close	8	
Output 3 throw	16	
Output 3 close	32	32
Output 4 throw	64	64
Output 4 close	128	
Program this value into CV33		101

Outputs 5 to 8	Value	Select
Output 5 throw	1	
Output 5 close	2	2
Output 6 throw	4	
Output 6 close	8	8
Output 7 throw	16	16
Output 7 close	32	
Output 8 throw	64	64
Output 8 close	128	
Program this value into CV34		90

Example: CV33 = 1 + 4 + 32 + 64 = 101, throw output 1, throw output 2, close output 3 and throw output 4
 Example: CV34 = 2 + 8 + 16 + 64 = 90, close output 5, close output 6, throw output 6 and throw output 6 (example shown above in table)

Tip: An easy way to program CV33 and CV34.
 1. Enter normal operating mode and command each of the outputs to the desired state.
 2. Enter programming mode and program CV29 to 2 (enable option 2).
 3. Exit programming mode.
 Now at each powered on, the outputs will go to the same state as set in step 1.

4.4 Decoder Configuration

CV29 - Configuration

This CV determines the decoder configuration options.

Option 1 - Memory. The SMD84 will remember the output state at power off and at power on the outputs will be set to the same state.

Option 2 - Default output state. At power on each output will be set to the state as determined by CV33 and CV34. You must program these CVs to the desired state. Option 2 disables option 1. See section 4.3.

Option 3 - Ops Mode Programming. Allows Operations mode (On the Main) programming using a Loco address to be enabled all the time. See section 4.10.

Option 4 - DCC to bus gateway. Allows DCC switch command packets to be put on the serial bus. Any device connected to the bus will have access to these DCC commands. Requires option 5.

Option 5 - Serial Bus communication. Allows the SMD84 to communication with devices connected to the serial bus.

Option 6 - DCC control. Allows the SMD84 to receive instructions from DCC (track).
Note: Selecting this option **DISABLES** this feature.

To calculate the value of CV29, add up the selected values. Example: Option 1 and option 3 - CV9 = 1 + 4 = 5

Decoder Configuration CV	Value	Select
No options	0	
Option 1 - Memory enabled	1	
Option 2 - Default output state enabled	2	
Option 3 - Ops mode programming enabled	4	
Option 4 - DCC to bus gateway enabled	8	
Option 5 - Serial Bus communication enabled	16	
Option 6 - Control from DCC DISABLED	32	
-	-	
Program this value into the configuration CV		

Select One

5.4 Input and Output

The primary input connector is a 10 pin flat ribbon cable (IDC) type. Jameco #138376 will work as the mating connector. 10 ft of gray flat ribbon cable is #135538. 10 ft of multicolor flat ribbon cable is #112547. Our cable connection kit (CCK) is available with 10' of multicolor cable and four connectors. If you want screw terminals for the primary inputs you can use our terminal strip adapter (TSA). The power, Aux inputs and outputs are spring type terminals.



Power Connector

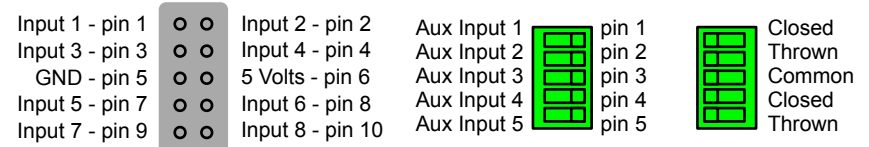

Input Connectors

Output Connectors

5.5 Serial Bus

The SMD84 has two RJ12 connectors for ease in making connections as shown below. In a Digitrax system the data pins are LocoNet® and the RS pins are Rail Sync. RS is not used by the SMD84. If you are using more than 10 SMD84s connected via the serial bus in a system the bus terminating resistor should be cut on any additional devices.

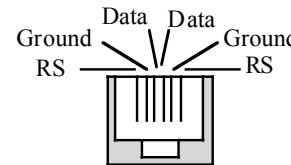

RJ12 Connector



Cables are wired pin 1 to pin 1

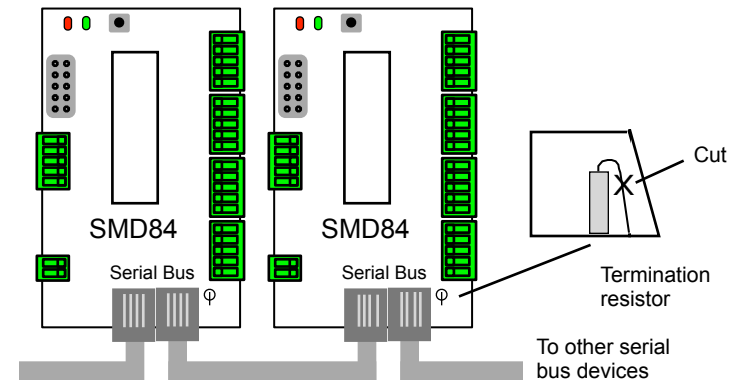

4.10 Ops Mode Address

CV31 - Ops mode address, a value of 1 to 127. Default is one (1). This CV sets the operations mode program address. Program the SMD84 just like you would a loco in ops mode. This is a loco 2 digit address and therefore must be unique among locomotive addresses. Option 3 must be enabled to use this address for programming on the main. The programming track is not required once this address and option 3 have been set. TIP: If the “Smart” program button is pressed before power is turned on then released when the green LED turns on, option 3 is enable until power is removed. This is useful if you do not want to have ops mode enabled all the time.

4.11 Input Lockout Address

CV100 - Address, value 0 to 255: CV101 - Address adder, value 0 to 7. These CVs set the input lockout address. When a turnout (switch) throw command is issued that matches this address the SMD84 primary and secondary inputs are disabled. When a close command is issued with this address the inputs are enabled. This feature is useful for dispatcher control when the SMD84 inputs are used for local turnout control.

4.12 Output On Time

CV2 - Output on time, a value of 1 to 127. This CV determines how long an output will stay on. In order for this CV to function the output configuration CV must be set to a value of two (2). See section 4.2. This CV applies to all outputs set to this configuration. The default value of this CV is 31 which gives an on time of about 8 seconds. The time is determine by the following equation.

$$\text{On time} = \text{CV2} \times .256 \text{ seconds}$$

5 Connections

5.1 Power

The SMD84 is recommended for HO and N scale. It should be connected to DCC track power for control via DCC. DCC track power also allows the CDU to charge to a higher voltage to give solenoid switch machines good performance. Use the two terminal spring type connector for power. The terms RAIL A and RAIL B are used for reference.



Power Connector

Maximum track voltage is 16 Volts.

5.2 Input Interface

Each primary and auxiliary input is at 5 volts when no device is connect. This is a hi or true state. When the input is connected to ground by a push button switch or block sensor the state is low or false. The secondary inputs are unique in that they share the same physical connection as the primary. They also require a resistor as shown in section 4.6.

5.3 Output Drive

The outputs can be configured to drive two types of switch machines; solenoid (twin coil) and stall motor (such as a Tortoise™). The common connection should ONLY be used for solenoid type.

Note: The SMD84 will not drive SwitchMaster, Scale Shops, Switch Tender or Fulgurex motors.

The following table will help you determine how to configuring the SMD84. If there are more than one SMD84 or other Gateway capable devices, only one should have the gateway enabled. In a Digitrax system DO NOT connect the SMD84 to the throttle Loconet if the gateway, DCC control and serial bus are enabled. This could cause an endless sending of switch commands from the track to Loconet and back to the track.

System	DCC Control Option 6	Gate-Way* Option 4	Serial Bus Option 5	CV Value	Notes
All DCC Compatible Systems	Enabled			0	The SMD84 is controlled via the track (DCC commands). The bus is not used by the SMD84.
Digitrax System	Disabled		Enabled	48	The SMD84 is controlled via Loconet.
Digitrax System	Enabled	Enabled	Enabled	24	Provides a separate Loconet bus for Loconet accessory devices. Allows devices to receive turnout commands from the track (DCC commands). Reduces throttle bus traffic. Easier trouble shooting.
NCE System and others	Enabled	Enabled	Enabled	24	Provides separate bus for bus enabled accessory devices. Allows devices to receive turnout commands from the track (DCC commands)

4.5 Status Report

CV28 - Status report. This CV determines which input and output states the SMD84 provides. This only works via the serial bus. Options 1 and 3 do NOT apply to inputs that are used for switch (turnout) control. Options 2 and 4 may NOT work correctly unless Decoder Configuration (section 4.4) option 1 or 2 is enabled.

Option 1 - Input state messages are sent on the serial bus at power on. This options is typically used for inputs that are used for block detection.

Option 2 - Output state messages are sent on the serial bus at power on. Unless the output states have been defined this will not work correctly. See section 4.4. These are switch type messages.

Option 3 - Input state messages are sent on the serial bus when a Digitrax interrogation command is received.

Option 4 - Output state messages are sent on the serial bus when a Digitrax interrogation command is received. These are feedback type messages.

Status Report CV	Value	Select
No options	0	
Option 1 - Send input state at power on enabled	1	
Option 2 - Send output state at power on enabled	2	
Option 3 - Interrogate input state enabled	4	
Option 4 - Interrogate output state enabled	8	
Program this value into the status report CV		

4.6 Input Control

These CVs determine what action the inputs will have when activated. There are three CVs for each input. An address, type and transition CV. See section 7 for CV numbers. Each input address is constructed of two CVs, an address and an address adder. See section 4.1. There are 13 physical input terminals. Eight primary and five auxiliary. If you require more than 13, you can use the secondary inputs which use the same terminal as the primary inputs but require the use of a resistor as shown in the diagram.

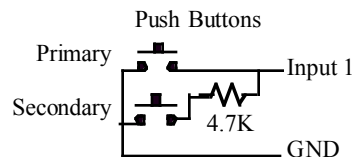

Each input can be programmed individually. In order to control an output the input must be programmed with the same address as the output with a message type of 'switch'.

The following table shows how each CV is defined and the value of each selection. Add the value of the selections together to determine the value to program the CV. In some cases only one of several selections are possible and are shown by a box as "Select one".

Pri, Sec & Aux Input Control		
Address CV	Value	Select
Address	1 - 255	1
Program this value into the appropriate address CV		1
Type CV	Value	Select
Invert the normal state	128	Select one
Normal state	0	0
Toggle state (only if switch type)	64	64
Message type, sensor	32	Select
Message type, feedback (actual switch position)	16	one
Message type, switch (commanded switch position)	0	0
Address adder (see the address adder table for amount to add)	0 - 9	
Program this value into the appropriate type CV		64
Transition CV	Value	Select
Send message on change transition	3	Select
Send message on hi to low transition	2	2
Send message on low to hi transition**	1	One
Disable message	0	
Program this value into the appropriate transition CV		2

** Not recommended for secondary inputs

In order for an input to cause an action, a transition must be selected. Each input has a 'pull-up' resistor connected to 5 volts, so the input is normally at 5 volts. An input transition is when the voltage on an input goes from high to low (falling edge) or from low to high (rising edge). For example, if a push button is connected to an input and ground, when it is pressed the input is grounded. This causes a high to low transition. When the button is released this causes a low to high transition.

Example: Primary input 1 when grounded will toggle output 1.

Address CV35=1, Type CV36=0+64+0=64, Transition CV37=2 (example shown above in table)

Note on toggle function: A push button may not always toggle the output on the first press. A second press may be necessary. This is because there is not a direct connection between

any given input and output. When an input sends a message whichever output, if any, will respond if there is an address match with type 'switch'. If there is no match nothing happens. The input does not know which, if any, output will respond. This concept of sending and receiving messages works with or without the serial bus enabled.

4.7 Route Execute Address

These CVs determine the top or execute address of a route. See section 7 for CV numbers. Each top address is completely independent of an input or output address. A route is executed when a turnout (switch) command from any source including those from the SMD84, throttles or computers matches the top address and switch state for that route. When a route is executed, turnout commands are sent for each cell containing an address. Optionally, a route can be executed by a block sensor message. In this way several turnouts can automatically be aligned when a block becomes occupied.

Route Top (Execute) Address		
Address CV	Value	Select
Address	1 - 255	
Program this value into the appropriate address CV		
Type CV	Value	Select
Close	64	Select one
Throw	0	
Execution type, sensor	32	Select one
Execution type, switch (switch command)	0	one
Address adder (see the address adder table for amount to add)	0 - 9	
Program this value into the appropriate type CV		

4.8 Route Cell Address

These CVs determine the address in a route cell. See section 7 for CV numbers. When a route is executed all cell addresses are sent one at a time. For all addresses in a route to be sent there must be no empty cells between cells with addresses.

Route Top (Execute) Address		
Address CV	Value	Select
Address	1 - 255	
Program this value into the appropriate address CV		
Type CV	Value	Select
Close	64	Select one
Throw	0	
Address adder (see the address adder table for amount to add)	0 - 9	
Program this value into the appropriate type CV		

4.9 Send Address Delay

CV99 - Send address time delay, value 0 to 255.

This CV determines the time delay the SMD84 waits before sending the next address in a route. A wye turnout or other brands of switch machine drivers may require a time delay between switch activation.

The delay is the CV99 value x 0.25 seconds.

Delay between sending route addresses								
CV11 Value	0	1	2	4	8	12	16	20
Delay (sec)	0	0.25	0.5	1	2	3	4	5