

Technical Reference

for the

**POWER PRO™**  
Digital Command Control

**D13SRP Decoder**

Dimensions:

1.65 x 0.630 x .120 inches

42 x 16.5 x 3.2 mm

**Decoder version 3.2**

**\$29.95**

**Convenient connection using NMRA 8 pin plug**

**This is an EPF (extended packet format) decoder supporting:**

- ✓ Silent Running™ motor drive eliminates annoying motor hum or buzz
- ✓ Directly replaces noisy Lenz LE103/LE103XF series decoders
- ✓ Programmable Start, Mid and Maximum speed works in all speed modes
- ✓ Motor rating 1.3 Amp continuous, 2 Amp peak (stall)
- ✓ All three function outputs have effects generators
- ✓ Select from 14 different lighting effects (Mars, strobes, beacons, etc)
- ✓ Function outputs can be mapped to different functions (highly compatible with Soundtraxx™ DSX decoders)
- ✓ Two or Four digit addressing
- ✓ Uploadable speed table interpolated to 128 speed steps
- ✓ 28 and 128 Speed mode operation (always works internally at 256 steps)
- ✓ Decoder assisted consisting
- ✓ All forms of operations mode programming (programming on the mainline)
- ✓ All forms of service mode programming (programming track)

Every attempt has been made to ensure this decoder complies with all applicable NMRA Standards and Recommended Practices. NMRA Conformance test results on this decoder are available on our website at [www.ncedcc.com](http://www.ncedcc.com)

This book, schematics and artwork copyright 1995-2001  
NCE Corporation Webster, NY 14580

### **Decoder Installation Notes:**

**Caution:** to avoid short circuits place a piece of ELECTRICAL TAPE on the bottom of the decoder to insulate it from the locomotive frame. Also, make sure there are no pinched wires between the decoder and frame or between the decoder and connector pins.

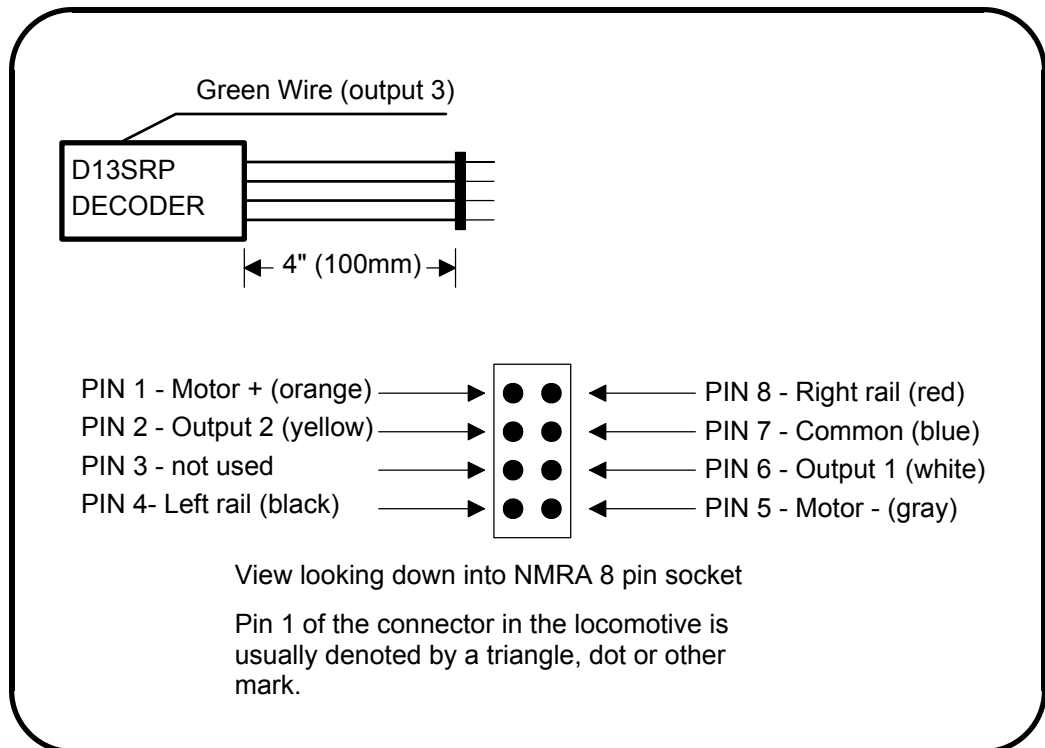

Plug the decoder in to the socket on the locomotive noting the pin 1 location. If you plug it in backwards no harm will be done but the locomotive will run backwards.

Before test running your newly converted locomotive on full power double check your wiring to make sure the motor is fully isolated and that there are no pinched or broken wires. We see many decoders returned due to wires getting pinched between the body shell and frame causing shorts.

Always test your decoder installation on an current limited programming track before trying it on full track power. If you have a Digitrax or MRC system that does not provide a current limited programming use a 100 Ohm resistor in series with one of the track leads and listen for the "click" that verifies correct operation as you program the decoder .

We recommend that the first "full power" testing be done on regular DC. If the pickup polarity is reversed you will want to correct this for proper analog mode operation. The decoders should be driven by a good quality smooth DC power unit. Power packs with pulse power systems such as "tracking control", etc. will give unpredictable operation. Analog operation is included in your North Coast Engineering decoders so you will be able to run on conventional layouts without having to remove the decoder or rewire your locomotive.

**Head and Rear Lights** We recommend Miniaturics #18-712-10[12v], #18-014-10 [14v] or Chicago Miniature white LEDs (Digikey [phone 800-344-4539 part number CMD204UWC). If you use an LED a 1K 1/4 Watt series resistor is required with each LED.

**Extra Function Output:** Due to the high in-rush current of incandescent grain-of-wheat type bulbs (about 10 times their normal operating current) function outputs are rated at 40mA each if used with incandescent bulbs. We recommend the Miniaturics part number mentioned above. If you wish to use 50-100mA rated lamps we recommend a 22 ohm 1/4 Watt resistor in series with each bulb (thiswill also greatly extend bulb life).

## Fine tuning locomotive operation

The factory settings of the P2k-sr normally provide good performance for most locomotives in HO-Scale. You may want to improve or fine tune performance by adjust the starting characteristics or top speed .

### There are five CVs that define:

- The voltage at which the motor starts
- How much 'kick' the motor gets to start it turning
- The maximum speed
- The response characteristics or 'speed curve'.
- The frequency of the drive pulses to the motor

### Start Voltage - CV2 (Vstart):

Before programming the start voltage we recommend programming CV65 (Kick Start) to zero. Kick start is used to overcome the 'stiction' of the motor by giving it a voltage 'kick' when starting from a stop. We don't want it getting in the way of setting Vstart.

We prefer using Operations Mode Programming (Program on the Main) to set CV2 so the locomotive is **just able** to maintain movement at speed step 1. You can also use the programming track... it just takes a bit longer to find the right setting for CV2.

### Kick Start - CV65

After the start voltage is set . Program CV65 to provide a smooth and reliable start when you advance the throttle from stop. The high frequency drive pulses of the D408SR act more like smooth DC voltage than the low frequency pulses of a standard decoder making it harder for the decoder to overcome that starting 'stiction' of the motor. This is why the Kick start CV is needed. If the value is too low the motor will not start moving reliably, too high and the locomotive will lurch or leap as it starts.

### Vmax - CV5:

If your locomotive runs too fast you can use CV5 to lower its maximum speed. Setting CV5 to 255 uses the maximum possible voltage to run the motor when full speed is requested. Set CV5 to a smaller value to reduce the top speed. A value of 128 will yield approximately ½ full voltage to the motor at top speed. 192 will provide about ¾ full voltage. All speeds from the middle speed step to the maximum will be proportionally reduced (see diagram). If CV5 is set to 0 the decoder will use 255 for maximum speed. Always make sure CV5 is greater than CV6 to avoid erratic operation.

### Vmid - CV6:

CV6 determines how the motor responds through its middle speed ranges to advancement of the throttle. If you set CV6 lower than half the maximum speed you'll have smaller increases in motor speed through the lower speed ranges. Then, as you hit the upper speed ranges there will be larger increases between speed steps. In the diagram below you can see this best illustrated by the factory default line. If you set Vstart larger than 0 you'll most likely want to raise Vmid so a reasonable slope is maintained in the 'speed curve'. If CV6 is set to 0 the decoder will use 127 as the value.

### Motor Drive Frequency - CV9:

When CV9 is set to 0 the Silent Running™ motor drive frequency of 15,625 Hz is used. If a value of 1-255 is programmed into CV9 the motor drive frequency will be calculated by the formula:  
Frequency = 1/(CV9 \* .000128).

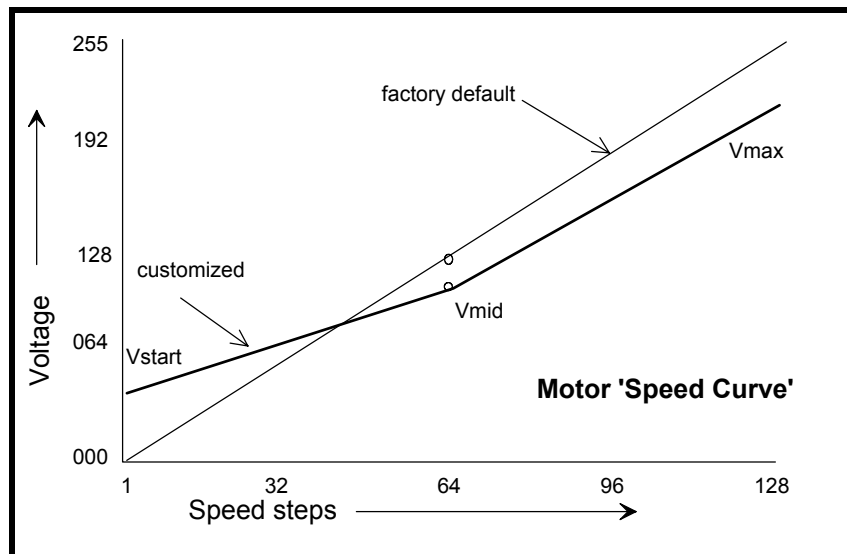

# Function mapping and effects programming examples

## Ditch lights:

What we want to do:

- ➔ Use outputs 2 and 3 (yellow and green wires) for the left and right ditch lights
- ➔ They will be controlled by F2 which is the HORN button on most DCC systems
- ➔ They should continue flashing for 5 seconds after the HORN button is released

How to do it:

- ✓ Program outputs 2 and 3 to both be activated by F2. Set the F2 mapping CV (CV36) to 6. We get the value of 6 by adding the 'bit weights' for output 2 and output 3 on the F2 line of the **CV mapping table** on page 6.
- ✓ Program outputs 2 and 3 for ditch light operation. Set CV121 to 56 and CV122 to 60. Using these values the lights will be 'qualified' by the headlight AND function 2. The headlight must be on for the ditch lights to be activated by F2. Type 1 ditch lights are on constantly on when the headlight is on and alternately flash when the horn is blown. Type 2 ditch lights are normally off until the horn is blown. This example is for the more common Type 1. If you prefer Type 2 use EFX values 52 and 48 instead of 60 and 56.
- ✓ CV118 sets the amount of time the ditch lights stay flashing after the horn (F2) is deactivated. The time is measured in 1/4 second intervals, for a hold time of 5 seconds put a value of 20 in the CV118.
- ✓ One last thing: Set CV34 to 0 so output 2 is not also controlled by F0
- ✓ One last thing: Set CV35 to 0 so output 2 is not also controlled by F1

## Mars Light:

What we want to do:

- ➔ Use output 3 (marked A on decoder) for a Mars light.
- ➔ It is to be on in the forward direction only

How to do it:

- ✓ Output 3 is already activated by F1 (factory default setting of CV35=4).
- ✓ Configure output 3 as a forward only Mars light. Set CV122 to 9. We get the value of 9 by using 8 (Mars Light) plus 1 (output operates only in forward direction)

## Rule 17 lighting:

Rule 17 refers to how the locomotive engineer operates the locomotive headlights during the running of the train. The rule varies from road to road but generally requires the dimming of the headlight(s) when in a siding waiting to meet another train, passing through passenger stations or moving within yard limits.

What we want to do:

- ➔ Use output 1 for the Headlight
- ➔ The headlight is to be on bright in both directions of locomotive travel
- ➔ We also want to be able dim the headlight

How to do it:

- ✓ Output 1 is already activated by F0 (factory default setting of CV33 =1).
- ✓ Configure output 1 as a standard output, on in both directions, yet dimmable when F4 is activated. Set CV120 to 32 (20 hex). You can optionally set CV120 to 36 is you want F8 to control the dimming instead of F4.
- ✓ Configure

## Switcher:

What we want:

- ➔ Headlights that dim in the opposite direction that the locomotive is travelling
- ➔ Use output 1 as Headlight and output 2 as Rearlight

How to do it:

- ✓ Outputs 1 and 2 are already activated by F0 due to the factory default settings.
- ✓ Configure output 1 as bright in forward dim in reverse . Set CV120 to 40 (28 hex)
- ✓ Configure output 2 as bright in reverse dim in forward . Set CV121 to 44 (2C hex)

## Description of EFX configuration CVs

- CV120 - Lighting effect configuration for output 1 (white wire).
- CV121 - Lighting effect configuration for output 2 (yellow wire).
- CV122 - Lighting effect configuration for output 3 (green wire).

Each output wire can select from 15 different lighting effects by using its associated EFX configuration CV. Pick the value for the CV from the table below, add 1 or 2 if you want the effect to be directional (footnotes 2 and 3), then add 128 if you are using a white LED for the effect. Ditch lights should not be made directional, they're not directional in real life.

<b>bit weight</b>	128	64	32	16	8	4	2	1
<b>bit name</b>	LED <sup>1</sup>	---	Effect configuration				REV <sup>2</sup>	FWD <sup>3</sup>

Value for CV	Description of lighting effect	Hex (for Digitrax users)
0	Standard on/off function output	0
4	reserved	4
8	Mars light	8
12	Rotary Beacon	0C
16	Gyralight	10
20	Double Strobe	14
24	Strobe A	18
28	Strobe B (alternates with Strobe A)	1C
32	Dim when F0 and F4 on, otherwise bright	20
36	Dim when F0 and F8 on, otherwise bright	24
40	Dim in forward, bright in reverse	28
44	Dim in reverse, bright in forward	2C
48	Type 2 Right Ditch light, effect on if F2 on, output off otherwise	30
52	Type 2 Left Ditch light, effect on if F2 on, output off otherwise	34
56	Type 1 Right Ditch light, effect on if F0 and F2 on, bright if F0 on and F2 off, off if F0 off	38
60	Type 1 Left Ditch light, effect if F2 and F0 on, bright if F0 on and F2 off, off if F0 off	3C

- 1** - Functions are designed to use 12-16 volt 30-40ma incandescent lamps. If you are using a white LED (with 1K limiting resistor) add 128 to the CV value.
- 2** - If you want the function to be active only in the reverse direction add 2 to the CV value
- 3** - If you want the function to be active only in the forward direction add 1 to the CV value

## Description of function mapping CVs:

*Function mapping* can change which output wire(s) are controlled by a function command from your handheld cab. It is possible to have one command control several outputs. In the tables below each row corresponds to a function mapping CV and each column indicates an output number. A '1' under an output number means that output will be controlled by the function corresponding to the row. In the table below the factory value of CV33 is 1 which means F0 will control Output #1.

Example: Say you have output 3 set to be a Mars Light (CV122=8) and you want it to come on when the headlight (F0) is on. In the CV33 row place a '1' in Output 3 column, there is already a '1' in the Output 1 column. Now F0 will control both Output 1 and Output 3. To calculate the value that goes in to CV33 just add up the 'bit weights' for each column that has a '1' in it. In the case of our example the value will be 5. F1 has been set at the factory to control Output 3 so you may want to put 00 in to CV35 to make sure Output 3 (Mars light) doesn't come on by accident if F1 is activated.

There are more examples of function mapping on page 4.

The tables below show the original factory settings for each mapping CV. The NMRA recommended practices do not provide for mapping all functions to all outputs. The tables below are the prescribed function mapping dictated by NMRA RP-9.2.2. Note: In this decoder CV33 and CV34 operate identically. They are not directional...directionality is provided in the EFX configuration CV for each output.

### Factory default function mapping values

Bit weight CV33-CV37	OUTPUT NUMBER		
	3	2	1
CV33 F0 Fwd	0	0	1
CV34 F0 Rev	0	1	0
CV35 F1	1	0	0
CV36 F2	0	0	0
CV37 F3	0	0	0

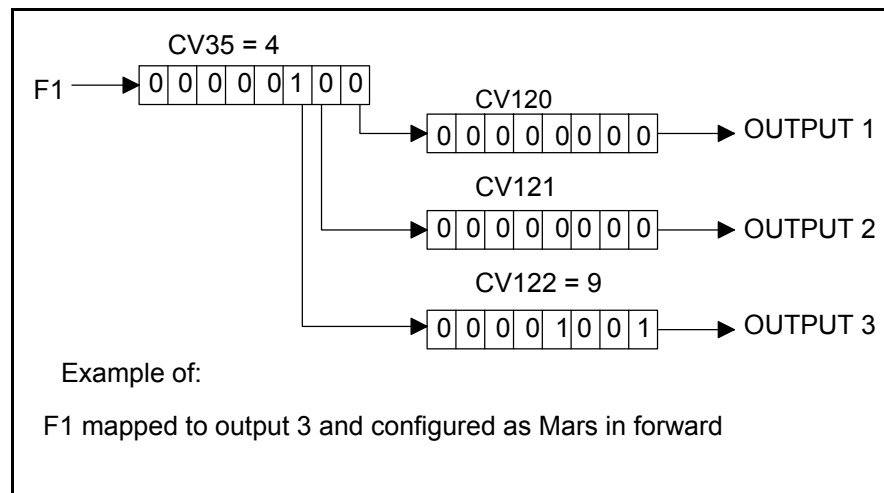

**About the function outputs:**

The rating of each function output on this decoder is 100mA continuous with a non-incandescent lamp (such as an LED) and 40mA with an incandescent lamp. The total allowable current that can be drawn by all functions is 300mA. We recommend Miniaturics part number 18-014-10 (2.4mm diameter 14 volt/30mA) or number 18-016-10 (2.4mm diameter 16 volt/30mA) bulbs for good results. If you wish to use 50-80mA rated lamps we suggest using a 22 ohm 1 Watt resistor in series with each bulb to greatly extend bulb life, especially if any lighting effects are used.

**Recommend dropping resistors if using 1.5 volt bulbs**

Bulb Current	Track Voltage								Wattage
	12.5	13	13.5	14	14.5	15	15.5	16	
15ma	680	680	720	750	820	820	910	910	¼ watt
30ma	330	360	360	390	390	430	430	470	½ watt
40ma	240	270	270	300	300	300	330	330	1 watt
50ma	200	200	220	220	240	240	270	270	1 watt
60ma	160	180	180	200	200	200	220	220	1 watt
80ma	120	130	130	150	150	160	160	160	2 watt

**Factory default values for decoder Configuration Variables (Cvs)**

CV	Default value		Description
	decimal	hex	
1	3	03	short address
2	0	00	start voltage
3	0	00	acceleration
4	0	00	deceleration
5	0	00	Maximum speed
6	0	00	Mid speed
9	0	00	PWM frequency
17	192	C0	long address high byte
18	0	00	long address low byte
19	0	00	consist address
21	255	FF	consist functions F1-F8
22	63	3F	consist function FLF,FLR
23	0	00	acceleration adjust
24	0	00	deceleration adjust
29	2	02	decoder configuration
30	0	00	reset/error register
33	1	01	Output(s) controlled by F0
34	2	02	Output(s) controlled by F0
35	0	04	Output(s) controlled by F1
36	0	0	Not used
37	0	0	Not used
38	0	0	Not used
39	0	0	Not used
40	0	0	Not used
41	0	0	Not used
42	0	0	Not used
65	0	00	Kick start
67	2	02	alt spd table step 1
68	5	05	alt spd table step 2
69	7	07	alt spd table step 3

CV	Default value		Description
	decimal	hex	
70	12	0C	alt spd table step 4
71	16	10	alt spd table step 5
72	21	15	alt spd table step 6
73	26	1A	alt spd table step 7
74	30	1E	alt spd table step 8
75	35	23	alt spd table step 9
76	40	28	alt spd table step 10
77	47	2F	alt spd table step 11
78	51	33	alt spd table step 12
79	58	3B	alt spd table step 13
80	65	41	alt spd table step 14
81	72	48	alt spd table step 15
82	79	1F	alt spd table step 16
83	84	54	alt spd table step 17
84	93	5D	alt spd table step 18
85	100	64	alt spd table step 19
86	112	70	alt spd table step 20
87	121	79	alt spd table step 21
88	135	87	alt spd table step 22
89	147	93	alt spd table step 23
90	161	A1	alt spd table step 24
91	177	B1	alt spd table step 25
92	196	C4	alt spd table step 26
93	219	DB	alt spd table step 27
94	255	FF	alt spd table step 28
118	20	14	Ditch light hold time
119	255	FF	EFX page access
120	1	01	Output 1 EFX generator
121	2	02	Output 2 EFX generator
122	0	00	Output 3 EFX generator

## **Configuration Variables used by D13 series Decoders**

- CV1** short decoder address; 1-127 valid  
**CV2** Start Voltage (useful range 0-100)  
**CV3** acceleration rate (each unit = 7mS between speed steps) 255 max.  
**CV4** deceleration rate (each unit = 7mS between speed steps) 255 max.  
**CV5** Vmax, speed at highest speed step. 0=use factory default of 255  
**CV6** Vmid, speed (on a scale of 1-255) at speed step 7,14,or 63. 0=use default of 128  
**CV7** Manufacturer ID. NCE = 11 (0B hex)  
**CV8** Decoder version number. This decoder is 32 which means version 3.2  
**CV9** Motor drive frequency  
- 1-255 = PWM drive frequency period in 128uS increments,  
- 0 = PWM frequency is 15,625 Hz  
**CV17** High byte of long (4 digit) address  
- bit 6,7 always= 1  
- bits 0-5 are upper 6 bits of address  
**CV18** low byte of long (4 digit) address  
**CV19** Consist address. (0 or 128 = no consist active)  
- bits 0-6 short consist address (1-127 valid)  
- bit 7 0= direction is normal, 1= direction is reversed  
**CV21** Functions active in consist mode. Bit 0 controls F1  
- bit 0 - 1=function can be controlled at consist address, 0 = no consist control  
**CV22** Functions active in consist mode. Bits 0,1 control FLF and FLR respectively  
- each bit 1=function can be controlled at consist address, 0 = no consist control  
**CV23** acceleration rate adjust (in 7mS increments) this value is added to CV3  
**CV24** deceleration rate adjust (in 7mS increments) this value is added to CV4  
**CV29** - bit 0 1= direction of operation is reversed, 0= direction is normal  
- bit 2 1= analog operation mode enabled, 0 = disabled  
- bit 4 1= alternate speed table active, 0= use table defined by CV2,5,6  
- bit 5 1= use long address in CV17/18, 0= use short address CV1  
- bits 1,3,6,7 are ignored by the decoder  
**CV33-CV35** function mapping CVs for F0-F1  
**CV65** Kick start - number of 1/1000s of a second to 'kick' motor when starting  
**CV67-CV94** Uploadable speed table steps 1-28 (128 speed mode calculates intermediate steps)  
**CV118** Ditch light hold time (in ¼ second increments) after F2 goes off.  
**CV119** Lighting effects page. Must be set to 255 for access to CVs120-127  
**CV120-CV122** Effects configuration registers for outputs 1-3

**CV NOTES:** All CV numbers not listed above are ignored.

**14 Speed mode** is scheduled to be dropped as a requirement by the NMRA. This decoder does not support headlight control in 14 speed mode. It *will* operate the motor and F1-F8 correctly with all systems however the headlight may not operate correctly with older systems.

**PROGRAMMING TRACK INFORMATION:** This decoder complies with NMRA RP-9.2.3 for all forms of paged, direct (bit and byte) and register mode programming.

**Ops mode programming (Programming on the Mainline):** Decoders do not respond to the long form ops mode programming instructions at their consist address (per RP-9.2.1). This is to avoid setting CV29 while in a consist then later wondering why the decoder now only responds to it's long address rather than the short or vice-versa.

**Tip for using consists and long (4 digit) addresses:** leave CV1 set to 3, or some other conveniently remembered address and only use the extended address (CV17, CV18) set to your desired value. This avoids mixing up normal 'short' addresses with consist addresses.

### **Warranty**

This decoder is fully factory tested and warranted against manufacturing defects for a period of 1 year. As the circumstances under which this decoder is installed can not be controlled, failure of the decoder due to installation problems can not be warranted. This includes misuse, miswiring, operation under loads beyond the design range of the decoder or short circuits in the locomotive manufacturer's factory wiring. If the decoder fails for non-warranted reasons NCE will replace the decoder, no questions asked, for \$10 U.S. plus \$2 shipping. For warranty or non-warranty replacement send the decoder (an any payment, if required) to:

**NCE Warranty Center**

**899 Ridge Road**

**Webster, New York 14580**

The terms Silent Running, Powerhouse Pro, Power Pro, Powerhouse Digital Command Control, ProCab, Switch-It, Snap-It, the NCE logo with "Power of DCC" slogan and EFX are trademarks of NCE Corporation. Master Series is service mark of NCE Corporation. Digitrax is a trademark of Digitrax Inc.