

NCE D14SR

The  Power of DCC

6 Function Decoder

\$29.95

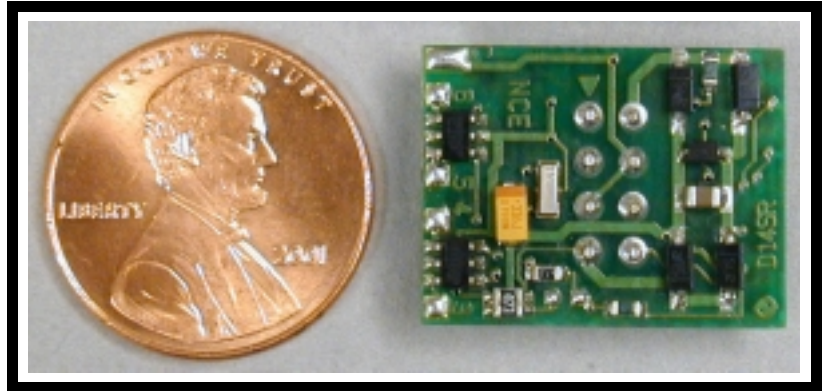

Decoder version 3.5

Dimensions: 0.820 x 0.630 inches - 21 x 16 mm

Designed specifically to fit decoders with an 8 pin socket such as:

Atlas GP40, AEM-7, GP7, U33C, U36C, C30-7, U23B

Kato RS2, RSC2, C44-9W, SD40-2, SD45

Bachmann Spectrum Steam Locomotives

LifeLike FA1, ER Models Sharknose, FP7

This is an EPF (extended packet format) decoder supporting:

- ✓ Silent Running™ motor drive
- ✓ Torque Compensation for ultra smooth low speed performance
- ✓ Programmable Start, Mid and Maximum speed works for all speed modes
- ✓ Motor rating 1 Amp continuous, 1.5 Amp peak (stall)
- ✓ All six function outputs have lighting effects generators
- ✓ Select from 15 different lighting effects (Mars, strobes, beacon, flicker, etc)
- ✓ Lighting outputs can be mapped to different functions
- ✓ Uploadable speed table interpolated to 128 speed steps
- ✓ Decoder assisted consisting
- ✓ Support for all forms of DCC programming
- ✓ Decoder programming lock mechanism
- ✓ Brake on DC feature assists automatic train control

Every attempt has been made to ensure this decoder complies with all applicable NMRA Standards and Recommended Practices. NMRA Conformance test results on this decoder are available on our website at www.ncedcc.com

This book, schematics and artwork copyright 2003
NCE Corporation Webster, NY 14580

Installation Notes:

This decoder is designed to plug straight in to locomotives with an NMRA 8 pin medium DCC socket. For locomotives without current limiting to 1.5 volt bulbs such as LifeLike Proto 2000 follow the manufacturers directions (included with the locomotive) for replacing the bulbs with proper lamps for DCC operation.

If the locomotive runs in the wrong direction reverse 180° the decoder in the locomotive. NOTE: this will also affect the direction the locomotive runs on an analog DC layout

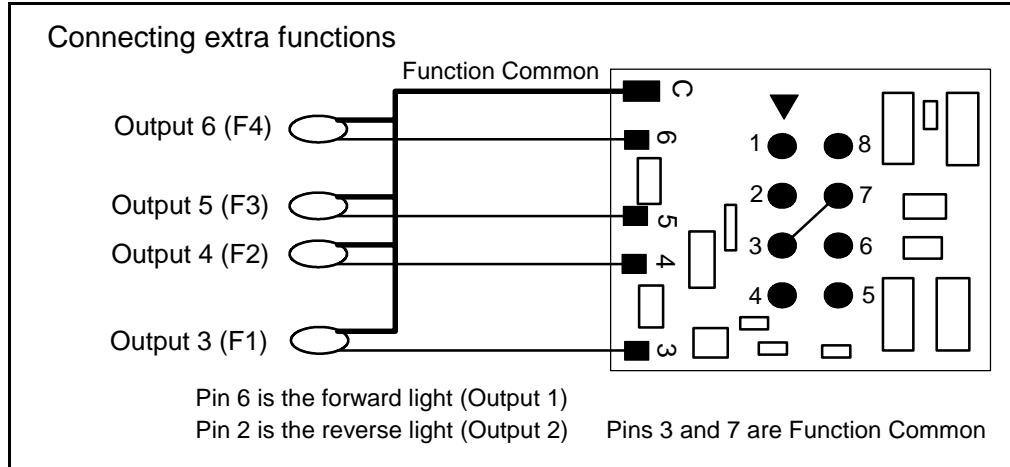

Before test running your newly converted locomotive on full power double check your wiring to make sure there are no pinched or broken wires. We see many decoders returned due to wires getting pinched between the body shell and frame causing shorts.

Always test your decoder installation on an current limited programming track before trying it on full track power.

We recommend that the first full power testing be done on regular DC. If the track pickup polarity is reversed you will want to correct this for proper analog mode operation. The decoders should be driven by a good quality smooth DC power unit. Power packs with pulse power systems such as "tracking control", etc. will give unpredictable operation.

DC Lighting:

This decoder remembers which functions are on or off between uses. If a function was on during DCC operation it will be on during DC operation. Lighting effects (Mars, flicker, etc) will also operate. Lighting effects work best in DC mode when used with LEDs.

Recommended Lighting:

If you use LEDs we recommend a 1K ohm 1/4 Watt series resistor in each function lead

- Miniatronics #12-310-05 Yellow Glo White LEDs.
- Richmond Controls (or equivalent) Golden White LEDs.
- Miniatronics #18-712-10 (12v) or #18-014-10 (14v) incandescent bulbs

Function output ratings: Due to the high in-rush current of incandescent grain-of-wheat type bulbs (about 10 times their normal operating current) function outputs are rated at 40mA each if used with incandescent bulbs. We recommend the Miniatronics part number mentioned above. If you wish to use 50-100mA rated lamps we recommend a 22 ohm 1/4 Watt series resistor in function leads with each bulb (this will also greatly extend bulb life).

Fine tuning locomotive operation

The factory settings normally provide good performance for most locomotives in H O-Scale. You may want to improve or fine tune performance by adjust the starting characteristics or top speed .

There are 6 CVs that define:

- The voltage at which the motor starts
- How often and how hard the motor gets kicked a slow speeds to keep it turning smoothly.
- The maximum motor speed
- The mid speed range response characteristics or 'speed curve'.
- Compensation for a motor that runs faster in one direction

Start Voltage - CV2 (Vstart):

This is the amount of voltage sent to the motor when first starting up. We set CV2 so the locomotive is **almost** able to maintain movement at speed step 1. We then use CV116 and 117 to apply enough torque compensation to keep it turning on speed step 1. Typical values for CV2 are in the range of 0-35.

Torque compensation kick rate - CV116:

How *frequently* the motor is 'kicked' at slow speed. Typical adjustment is 2 to 4. The smaller the number the more often the motor gets a brief voltage 'kick'. Factory default is 0 (off). A value of 1 applies kicks continuously. The maximum practical value is about 6.

Torque compensation kick strength - CV117:

How *hard* the motor is 'kicked' at slow speed. Typical adjustment is 4 to 25 The larger the number the more voltage is applied in each 'kick'. The strength of these kicks fade out ratiometrically as speed is increased providing a smooth transition to normal motor operation. Factory default is 0 (off), usable range 0-50.

Vmax - CV5: If your locomotive runs too fast you can use CV5 to lower its maximum speed.

Setting CV5 to 255 uses the maximum possible voltage to run the motor when full speed is requested. Set CV5 to a smaller value to reduce the top speed. A value of 128 will yield approximately $\frac{1}{2}$ full voltage to the motor at top speed. 192 will provide about $\frac{3}{4}$ full voltage. All speeds from the middle speed step to the maximum will be proportionally reduced (see diagram). If CV5 is set to 0 the decoder will use 255 for maximum speed. Always make sure CV5 is greater than CV6 to avoid erratic operation.

Vmid - CV6: CV6 determines how the motor responds through its middle speed ranges to advancement of the throttle. If you set CV6 lower than half the maximum speed you'll have smaller increases in motor speed through the lower speed ranges. Then, as you hit the upper speed ranges there will be larger increases between speed steps. In the diagram below you can see this best illustrated by the 'customized' line. If you set Vstart larger than 0 you'll most likely want to raise Vmid so a reasonable slope is maintained in the 'speed curve'. If CV6 is set to 0 the decoder will use 127 as the value. If you use high values in CV117 you will want to increase CV6 by a proportional amount to keep a smooth acceleration curve.

Reverse trim (also forward trim) - CV95:

Values from 1-127 make decoder run **faster in reverse** than forward. 1 is one speed step faster in reverse, 2 is two steps faster, etc.

Values from 129-255 make decoder run **faster in forward** than reverse. 129 is one speed step faster in forward, 130 is 2 speed steps faster, etc. 0 and 128 add nothing to either direction .

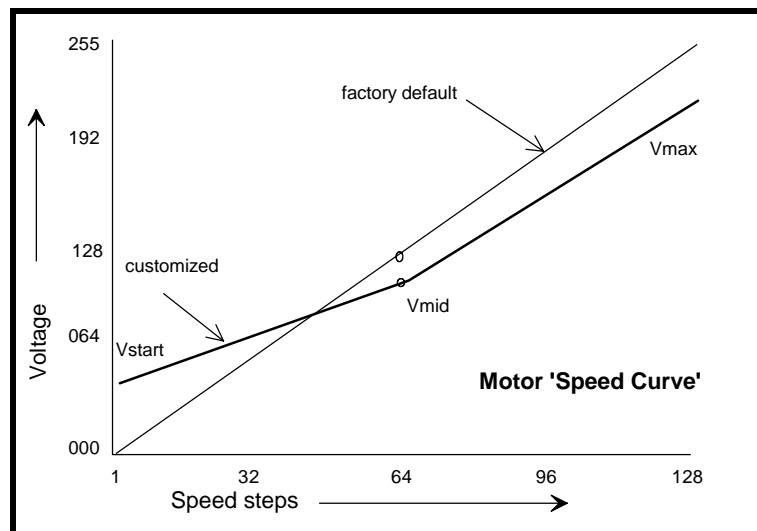

Effects programming (and function mapping) examples

Ditch lights:

What we want to do:

- ➔ Use outputs 3 and 4 for the left and right ditch lights
- ➔ They will be controlled by F2 which is the HORN button on most DCC systems
- ➔ They should continue flashing for 5 seconds after the HORN button is released

How to do it:

- ✓ Program outputs 3 and 4 to both be activated by F2. Set the F2 mapping CV (CV36) to 12. We get the value of 12 by adding the values for output 3 and output 4 on the F2 line of the **CV mapping table** on page 6.
- ✓ Program outputs 3 and 4 for ditch light operation. Set CV122 to 56 and CV123 to 60. Using these values the lights will be 'qualified' by the headlight AND function 2. The headlight must be on for the ditch lights to be activated by F2. Type 1 ditch lights are on constantly on when the headlight is on and alternately flash when the horn is blown. Type 2 ditch lights are normally off until the horn is blown. This example is for the more common Type 1. If you prefer Type 2 use EFX values 52 and 48 instead of 60 and 56.
- ✓ CV118 sets the amount of time the ditch lights stay flashing after the horn (F2) is deactivated. The time is measured in 1/4 second intervals, for a hold time of 5 seconds put a value of 20 in the CV118.
- ✓ One last thing: Set CV35 to 0 so output 3 is not also controlled by F1

Mars Light:

What we want to do:

- ➔ Use output 3 (marked A on decoder) for a Mars light.
- ➔ It is to be on in the forward direction only

How to do it:

- ✓ Output 3 is already activated by F1 (factory default setting of CV35=4).
- ✓ Configure output 3 as a forward only Mars light. Set CV122 to 9. We get the value of 9 by using 8 (Mars Light) plus 1 (output operates only in forward direction)

Rule 17 lighting:

Rule 17 refers to how the locomotive engineer operates the locomotive headlights during the running of the train. The rule varies from road to road but generally requires the dimming of the headlight(s) when in a siding waiting to meet another train, passing through passenger stations or moving within yard limits.

What we want to do:

- ➔ Use output 1 for the Headlight
- ➔ The headlight is to be on bright in both directions of locomotive travel
- ➔ We also want to be able dim the headlight
- ➔ Use output 2 for the rear light. It is to come on in reverse, off in forward

How to do it:

- ✓ Output 1 is already activated by F0 (factory default setting of CV33 =1).
- ✓ Configure output 1 as a standard output, on in both directions, yet dimmable when F4 is activated. Set CV120 to 32 (20 hex). You can optionally set CV120 to 36 is you want F8 to control the dimming instead of F4.
- ✓ Configure the rear light to be on in reverse and off in forward operation: Set CV121 to 2

Switcher:

What we want:

- ➔ Headlights that dim in the opposite direction that the locomotive is travelling
- ➔ Use output 1 as Headlight and output 2 as Rearlight

How to do it:

- ✓ Outputs 1 and 2 are already activated by F0 due to the factory default settings.
- ✓ Configure output 1 as bright in forward dim in reverse. Set CV120 to 44 (2C hex)
- ✓ Configure output 2 as bright in reverse dim in forward. Set CV121 to 40 (28 hex)

Description of EFX configuration CVs

- CV120 - Lighting effect configuration for output 1 (pin 7 of 8 pin connector).
- CV121 - Lighting effect configuration for output 2 (pin 2 of 8 pin connector).
- CV122 - Lighting effect configuration for output 3 (solder pad marked "3").
- CV123 - Lighting effect configuration for output 4 (solder pad marked "4").
- CV124 - Lighting effect configuration for output 5 (solder pad marked "5").
- CV125 - Lighting effect configuration for output 6 (solder pad marked "6").

Each output wire can select from 15 different lighting effects by using its associated EFX configuration CV. Pick the value for the CV from the table below, add 1 or 2 if you want the effect to be directional (footnotes 2 and 3), then add 128 if you are using a white LED for the effect. Ditch lights should not be made directional, they're not directional in real life.

| | | | | | | | | |
|-------------------|------------------|-----|----------------------|----|---|---|------------------|------------------|
| bit weight | 128 | 64 | 32 | 16 | 8 | 4 | 2 | 1 |
| bit name | LED ¹ | --- | Effect configuration | | | | REV ² | FWD ³ |

| Value for CV | Description of lighting effect | Hex (for Digitrax users) |
|--------------|--|--------------------------|
| 0 | Standard on/off function output | 0 |
| 4 | Firebox flicker (brighter when accelerating) | 4 |
| 8 | Mars light | 8 |
| 12 | Rotary Beacon | 0C |
| 16 | Gyalight | 10 |
| 20 | Double Strobe | 14 |
| 24 | Strobe A | 18 |
| 28 | Strobe B (alternates with Strobe A) | 1C |
| 32 | Dim when F0 and F4 on, otherwise bright | 20 |
| 36 | Dim when F0 and F8 on, otherwise bright | 24 |
| 40 | Dim in forward, bright in reverse | 28 |
| 44 | Dim in reverse, bright in forward | 2C |
| 48 | Type 2 Right Ditch light, effect on if F2 on, output off otherwise | 30 |
| 52 | Type 2 Left Ditch light, effect on if F2 on, output off otherwise | 34 |
| 56 | Type 1 Right Ditch light, effect on if F0 <i>and</i> F2 on, bright if F0 on <i>and</i> F2 off, off if F0 off | 38 |
| 60 | Type 1 Left Ditch light, effect if F2 <i>and</i> F0 on, bright if F0 on <i>and</i> F2 off, off if F0 off | 3C |

- 1** - Functions are designed to use 12-16 volt 30-40ma incandescent lamps. If you are using a white LED (with 1K limiting resistor) add 128 to the CV value.
- 2** - If you want the function to be active only in the reverse direction add 2 to the CV value
- 3** - If you want the function to be active only in the forward direction add 1 to the CV value

Description of function mapping CVs:

Function mapping can change which outputs are controlled by a function command from your handheld cab. It is possible to have one command control several outputs. In the table below each row corresponds to a function mapping CV and each column indicates an output number. The **bold** number in a column is the factory default. Programming the CV to the value under an output number will change that output to be controlled by that function number. In the table below the factory value of CV35 is 4 which means F1 will control Output #3. If you want F1 to control output 4 program CV35 to 8. If you want F1 to control both outputs 3 and 4 add the two values for those outputs together (4+8=12) and program CV35 with 12.

Note in this decoder CV33 and CV34 operate identically. They are not directional...directionality is provided in the EFX configuration CV for each output.

Factory default function mapping values

| | OUTPUT NUMBER | | | | | |
|-------------|---------------|-----------|----------|----------|----------|----------|
| | 6 | 5 | 4 | 3 | 2 | 1 |
| CV33 F0 Fwd | 32 | 16 | 8 | 4 | 2 | 1 |
| CV34 F0 Rev | 32 | 16 | 8 | 4 | 2 | 1 |
| CV35 F1 | 32 | 16 | 8 | 4 | 2 | 1 |
| CV36 F2 | 32 | 16 | 8 | 4 | 2 | 1 |
| CV37 F3 | 32 | 16 | 8 | 4 | 2 | 1 |
| CV38 F4 | 4 | 2 | 1 | | | |
| CV39 F5 | 4 | 2 | 1 | | | |
| CV40 F6 | 4 | 2 | 1 | | | |

Recommend dropping resistors if using 1.5 volt bulbs

| Bulb Current | Track Voltage | | | | | | | | Wattage |
|--------------|---------------|-----|------|-----|------|-----|------|-----|---------|
| | 12.5 | 13 | 13.5 | 14 | 14.5 | 15 | 15.5 | 16 | |
| 15ma | 680 | 680 | 720 | 750 | 820 | 820 | 910 | 910 | ¼ watt |
| 30ma | 330 | 360 | 360 | 390 | 390 | 430 | 430 | 470 | ½ watt |
| 40ma | 240 | 270 | 270 | 300 | 300 | 300 | 330 | 330 | 1 watt |
| 50ma | 200 | 200 | 220 | 220 | 240 | 240 | 270 | 270 | 1 watt |
| 60ma | 160 | 180 | 180 | 200 | 200 | 200 | 220 | 220 | 1 watt |
| 80ma | 120 | 130 | 130 | 150 | 150 | 160 | 160 | 160 | 2 watt |

Factory default values for decoder Configuration Variables (CVs)

| CV | Default value | | Description | CV | Default value | | Description |
|----|---------------|-----|----------------------------|-----|---------------|-----|------------------------|
| | decimal | hex | | | decimal | hex | |
| 1 | 3 | 03 | short address | 71 | 0 | 0 | alt spd table step 5 |
| 2 | 0 | 00 | start voltage | 72 | 0 | 0 | alt spd table step 6 |
| 3 | 0 | 00 | acceleration | 73 | 0 | 0 | alt spd table step 7 |
| 4 | 0 | 00 | deceleration | 74 | 0 | 0 | alt spd table step 8 |
| 5 | 0 | 00 | maximum speed | 75 | 0 | 0 | alt spd table step 9 |
| 6 | 0 | 00 | mid speed | 76 | 0 | 0 | alt spd table step 10 |
| 7 | 35 | 23 | decoder version | 77 | 0 | 0 | alt spd table step 11 |
| 11 | 0 | 00 | Packet timeout value | 78 | 0 | 0 | alt spd table step 12 |
| 15 | 0 | 00 | Programming "key" | 79 | 0 | 0 | alt spd table step 13 |
| 16 | 0 | 00 | Programming "lock" | 80 | 0 | 0 | alt spd table step 14 |
| 17 | 192 | C0 | long address high byte | 81 | 0 | 0 | alt spd table step 15 |
| 18 | 0 | 00 | long address low byte | 82 | 0 | 0 | alt spd table step 16 |
| 19 | 0 | 00 | consist address | 83 | 0 | 0 | alt spd table step 17 |
| 21 | 255 | FF | consist functions F1-F8 | 84 | 0 | 0 | alt spd table step 18 |
| 22 | 63 | 3F | consist function FLF,FLR | 85 | 0 | 0 | alt spd table step 19 |
| 23 | 0 | 00 | acceleration adjust | 86 | 0 | 0 | alt spd table step 20 |
| 24 | 0 | 00 | deceleration adjust | 87 | 0 | 0 | alt spd table step 21 |
| 29 | 6 | 06 | decoder configuration | 88 | 0 | 0 | alt spd table step 22 |
| 30 | 0 | 00 | error/reset register | 89 | 0 | 0 | alt spd table step 23 |
| 33 | 1 | 01 | Output(s) controlled by F0 | 90 | 0 | 0 | alt spd table step 24 |
| 34 | 2 | 02 | Output(s) controlled by F0 | 91 | 0 | 0 | alt spd table step 25 |
| 35 | 4 | 04 | Output(s) controlled by F1 | 92 | 0 | 0 | alt spd table step 26 |
| 36 | 8 | 08 | Output(s) controlled by F2 | 93 | 0 | 0 | alt spd table step 27 |
| 37 | 16 | 10 | Output(s) controlled by F3 | 94 | 0 | 0 | alt spd table step 28 |
| 38 | 4 | 04 | Output(s) controlled by F4 | 95 | 0 | 0 | reverse trim |
| 39 | 8 | 08 | Output(s) controlled by F5 | 116 | 0 | 0 | torque kick rate |
| 40 | 16 | 10 | Output(s) controlled by F6 | 117 | 0 | 0 | torque kick strength |
| 41 | 0 | 0 | not used | 118 | 20 | 14 | ditch light hold time |
| 42 | 0 | 0 | not used | 120 | 1 | 01 | output 1 EFX generator |
| 67 | 0 | 0 | alt spd table step 1 | 121 | 2 | 02 | output 2 EFX generator |
| 68 | 0 | 0 | alt spd table step 2 | 122 | 0 | 00 | output 3 EFX generator |
| 69 | 0 | 0 | alt spd table step 3 | 123 | 0 | 00 | output 4 EFX generator |
| 70 | 0 | 0 | alt spd table step 4 | 124 | 0 | 00 | output 5 EFX generator |
| | | | | 125 | 0 | 00 | output 6 EFX generator |

Configuration of CV29 settings:

Table of commonly used values for CV29

| Value for CV29 | | Long/Short Address | Uploadable/Factory Speed table | Analog (DC) operation | Speed mode |
|----------------|-----|--------------------|--------------------------------|-----------------------|------------|
| decimal | hex | | | | |
| 0 | 2 | Short | Factory | no | 28/128 |
| 6 | 6 | Short | Factory | yes | 28/128 |
| 18 | 12 | Short | Uploadable | no | 28/128 |
| 22 | 16 | Short | Uploadable | yes | 28/128 |
| 34 | 22 | Long | Factory | no | 28/128 |
| 38 | 26 | Long | Factory | yes | 28/128 |
| 50 | 32 | Long | Uploadable | no | 28/128 |
| 54 | 36 | Long | Uploadable | yes | 28/128 |

Hex numbers are provided for early Digitrax users

Notes:

- If you want to reverse the direction of travel on DCC increase the value for CV29 by one (this also reverses all directional lighting).
- If you want to reverse the DC direction reverse the track pickup wires.

Configuration Variables used by V3.5 Decoders

- CV1** Short decoder address; 1-127 valid
CV2 Start Voltage (useful range 0-100)
CV3 Acceleration rate (each unit = 7mS between speed steps) 255 max.
CV4 Deceleration rate (each unit = 7mS between speed steps) 255 max.
CV5 Vmax, speed at highest speed step. 0=use factory default of 255
CV6 Vmid, speed (on a scale of 1-255) at speed step 7,14,or 63. 0=use default of 127
CV7 Decoder version number. This decoder is 35 which means version 3.5
CV8 Manufacturer ID. NCE = 11 (0B hex)
CV11 Packet timeout value (in ½ second increments) Time the decoder will wait before braking to a stop after running into a section of track with DC power. 0=Don't brake
CV15 Decoder programming lock "KEY". This CV is always programmable even when "locked"
CV16 Decoder programming lock ID. When CV15=CV16, programming is unlocked and the decoder will respond to programming commands. If CV15 is not equal to CV16 then decoder programming is locked and it will not program (except CV15) or read.
CV17 High byte of long (4 digit) address
- bit 6,7 always= 1
- bits 0-5 are upper 6 bits of address
CV18 Low byte of long (4 digit) address
CV19 Consist address. (0 or 128 = no consist active)
- bits 0-6 short consist address (1-127 valid)
- bit 7 0= direction is normal, 1= direction is reversed
CV21 Functions active in consist mode. Bit 0 controls F1, bit 1=F2, bit 2=F3, etc.
- bit 0 - 1=function can be controlled at consist address, 0 = no consist control
CV22 Functions active in consist mode. Bits 0,1 control FLF and FLR respectively
each bit 1=function can be controlled at consist address, 0 = no consist control
CV29 - bit 0 1= direction of operation is reversed, 0= direction is normal
- bit 1 1=28 speed mode (always enabled)
- bit 2 1= analog operation mode enabled, 0 = disabled
- bit 4 1= alternate speed table active, 0= use table defined by CV2,5,6
- bit 5 1= use long address in CV17/18, 0= use short address CV1
- bits 3,6,7 are ignored by the decoder
CV30 Set this CV to 2 **on the programming track** and the decoder will reset to factory settings.
CV33-CV40 function mapping CVs for F0-F6
CV67-CV94 Uploadable speed table steps 1-28 (128 speed mode calculates intermediate steps)
CV95 Reverse trim, values 1-127 add to reverse speed, values 129-255 add to forward speed
CV116 Torque kick rate - number of 16ms periods in a row that motor is 'kicked' with voltage pulse
CV117 Torque kick strength - how much voltage is used to kick the motor at slow speeds. Reduces to 0 as speed is increased.
CV118 Ditch light hold time (in ¼ second increments) after F2 goes off.
CV120-CV125 Effects configuration registers for outputs 1-6

CV NOTES: All CV numbers not listed above may be programmed but not used by the decoder. This decoder supports all DCC programming methods.

Formula for computing the long address if using a Lenz SET01 or SET02:

If using a Lenz SET01, SET02, SET90, SET100 or other entry level system, use paged programming mode and see below for programming long addresses.

CV17 = 192 + (the whole number portion of the long address divided by 256)

CV18 = the remainder after the long address is divided by 256

CV29 = 34 if analog mode disabled, 38 if analog mode enabled

Decoder Warranty

This decoder is fully factory tested and warranted against manufacturing defects for a period of 1 year. As the circumstances under which this decoder is installed can not be controlled, failure of the decoder due to installation problems can not be warranted. This includes misuse, miswiring, operation under loads beyond the design range of the decoder or short circuits in the locomotive manufacturer's factory wiring. If the decoder fails for non-warranted reasons NCE will replace the decoder, no questions asked, for \$10 U.S. plus \$2 shipping. For warranty or non-warranty replacement send the decoder (and any payment, if required) to:

NCE Warranty Center
899 Ridge Road
Webster, New York 14580

Bar Code

The terms Silent Running, Powerhouse Pro, Power Pro, SmartCab, ProCab, Switch-It, Snap-It, the NCE logo with "Power of DCC" slogan and EFX are trademarks of NCE Corporation. Digitrax is a trademark of Digitrax Inc.