

## Configuration Variables used by V3.5 Decoders

- CV1 Short decoder address; 1-127 valid  
CV2 Start Voltage (useful range 0-100)  
CV3 Acceleration rate (each unit = 7mS between speed steps) 255 max.  
CV4 Deceleration rate (each unit = 7mS between speed steps) 255 max.  
CV5 Vmax, speed at highest speed step. 0=use factory default of 255  
CV6 Vmid, speed (on a scale of 1-255) at speed step 7,14, or 63. 0=use default of 127  
CV7 Decoder version number. This decoder is 35 which means version 3.5  
CV8 Manufacturer ID. NCE = 11 (0B hex)  
CV11 Packet timeout value (in ½ second increments) Time the decoder will wait before braking to a stop after running into a section of track with DC power. 0=Don't brake  
CV15 Decoder programming lock "KEY". This CV is always programmable even when "locked"  
CV16 Decoder programming lock ID. When CV15=CV16, programming is unlocked and the decoder will respond to programming commands. If CV15 is not equal to CV16 then decoder programming is locked and it will not program (except CV15) or read.  
CV17 High byte of long (4 digit) address  
- bit 6,7 always= 1  
- bits 0-5 are upper 6 bits of address  
CV18 Low byte of long (4 digit) address  
CV19 Consist address. (0 or 128 = no consist active)  
- bits 0-6 short consist address (1-127 valid)  
- bit 7 0= direction is normal, 1= direction is reversed  
CV21 Functions active in consist mode. Bit 0 controls F1, bit 1=F2, bit 2=F3, etc.  
- bit 0 - 1=function can be controlled at consist address, 0 = no consist control  
CV22 Functions active in consist mode. Bits 0,1 control FLF and FLR respectively  
each bit 1=function can be controlled at consist address, 0 = no consist control  
CV29 - bit 0 1= direction of operation is reversed, 0= direction is normal  
- bit 1 1=28 speed mode (always enabled)  
- bit 2 1= analog operation mode enabled, 0 = disabled  
- bit 4 1= alternate speed table active, 0= use table defined by CV2,5,6  
- bit 5 1= use long address in CV17/18, 0= use short address CV1  
- bits 3,6,7 are ignored by the decoder  
CV30 Set this CV to 2 on the programming track and the decoder will reset to factory settings.  
CV33-CV40 function mapping CVs for F0-F6  
CV67-CV94 Uploadable speed table steps 1-28 (128 speed mode calculates intermediate steps)  
CV95 Reverse trim, values 1-127 add to reverse speed, values 129-255 add to forward speed  
CV116 Torque kick rate - number of 16ms periods in a row that motor is 'kicked' with voltage pulse  
CV117 Torque kick strength - how much voltage is used to kick the motor at slow speeds. Reduces to 0 as speed is increased.  
CV118 Ditch light hold time (in ¼ second increments) after F2 goes off.  
CV120-CV123 Effects configuration registers for outputs 1-4

CV NOTES: All CV numbers not listed above are ignored. This decoder supports all DCC programming methods.

### Formula for computing the long address if using a Lenz SET01 or SET02:

If using a Lenz SET01, SET02, SET90, SET100 or other entry level system, use paged programming mode and see below for programming long addresses.

CV17 = 192 + (the whole number portion of the long address divided by 256)

CV18 = the remainder of the long address divided by 256

CV29 = 34 if analog mode disabled, 38 if analog mode enabled

:

### Decoder Warranty

This decoder is fully factory tested and warranted against manufacturing defects for a period of 1 year. As the circumstances under which this decoder is installed can not be controlled, failure of the decoder due to installation problems can not be warranted. This includes misuse, miswiring, operation under loads beyond the design range of the decoder or short circuits in the locomotive manufacturer's factory wiring. If the decoder fails for non-warranted reasons NCE will replace the decoder, no questions asked, for \$10 U.S. plus \$2 shipping. For warranty or non-warranty replacement send the decoder (and any payment, if required) to:

NCE Warranty Center  
82 Main Street  
Webster, New York 14580



05240132

The terms Silent Running, Powerhouse Pro, Power Pro, ProCab, Power Cab, the NCE logo with "Power of DCC" slogan and the distinctive shape of the ProCab with thumbwheel and LCD are trademarks of NCE Corporation. Digitrax is a trademark of Digitrax Inc.



# N14SRP Decoder

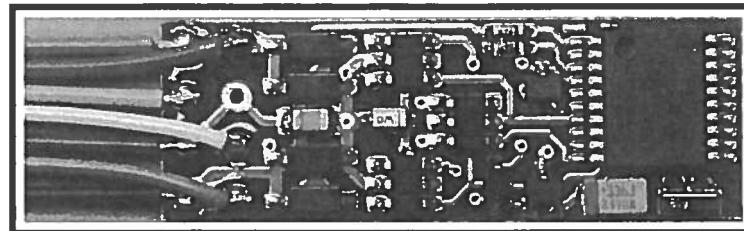

**\$35.95**

Decoder version 3.5

Dimensions: 1.15 x 0.34 x .12 inches - 29 x 10.2 x 2.9 mm

**Four function decoder with 8 pin NMRA plug makes it easy to install in N and small HO locomotives**

### Features of this decoder::

- ✓ Silent Running™, torque compensated motor drive
- ✓ Torque Compensation for ultra smooth low speed performance
- ✓ Motor rating 1.3 Amp continuous, 2 Amp peak (stall)
- ✓ All four function outputs have lighting effects generators
- ✓ Select from 15 different lighting effects
- ✓ Full support for LED lighting
- ✓ Decoder programming lock mechanism



05240132



This book, schematics and artwork copyright 2009 NCE Corp., Webster, NY 14580

**Warning:** This product contains chemicals known to the state of California to cause cancer, birth defects or other reproductive harm.

### Decoder Installation Notes:

The N14SRP decoder is covered with heat shrink tubing to protect it from short circuits to the locomotive frame or wiring in the locomotive.

Plug the decoder in to the socket on the locomotive noting the pin 1 location. If you plug it in backwards no harm will be done but the locomotive will run backwards.

Before test running your newly converted locomotive on full power double check your wiring to make sure the motor is fully isolated and that there are no pinched or broken wires. We see many decoders returned due to wires getting pinched between the body shell and frame causing shorts.

The most important part of a successful decoder installation is proper isolation of both motor brushes from the track wiring so that they are driven only by the decoder. Failure to isolate the motor will definitely damage the decoder. Damage caused by failure to isolate the motor is not covered by the decoder warranty.

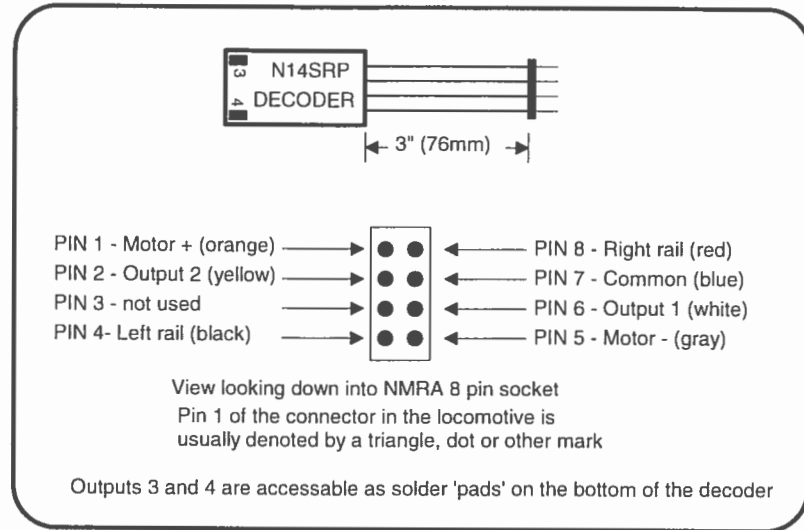

Before test running your newly converted locomotive on full power double check your wiring to make sure the motor is fully insulated from the frame and that there are no pinched or broken wires. We see many decoders returned due to wires getting pinched between the body shell and frame causing shorts.

Always test your decoder installation on an current limited programming track before trying it on full track power.

We recommend that the first full power testing be done on regular DC (units come factory setup to run on DC layouts). If the track pickup polarity (red and black wires) is reversed you will want to correct this for proper analog mode operation. The decoders should be driven by a good quality smooth DC power unit. Power packs with pulse power systems such as "tracking control", etc. will give unpredictable operation.

### Recommended Lighting:

If you use LEDs we recommend a 1K ohm 1/4 Watt series resistor in each function lead

→ Miniaturics #12-310-05 Yellow Glo White LEDs.

→ Miniaturics #18-712-10 (12v) or #18-014-10 (14v) incandescent bulbs

**Function output ratings:** Due to the high in-rush current of incandescent grain-of-wheat type bulbs (about 10 times their normal operating current) function outputs are rated at 50mA each if used with incandescent bulbs. We recommend the Miniaturics part number mentioned above. If you wish to use 60-100mA rated lamps we recommend a 22 ohm 1/4 Watt series resistor in function leads with each bulb (this will also greatly extend bulb life).

### Function Outputs 3 and 4:

These two outputs are made available as two "solder pads" at the end of the decoder

### Factory default values for decoder Configuration Variables (CVs)

CV	Default value		Description
	decimal	hex	
1	3	03	short address
2	0	00	start voltage
3	0	00	acceleration
4	0	00	deceleration
5	0	00	maximum speed
6	0	00	mid speed
7	35	23	decoder version
11	0	00	Packet timeout value
15	0	00	Programming "key"
16	0	00	Programming "lock"
17	192	C0	long address high byte
18	0	00	long address low byte
19	0	00	consist address
21	255	FF	consist functions F1-F8
22	63	3F	consist function FLF,FLR
23	0	00	acceleration adjust
24	0	00	deceleration adjust
29	2	02	decoder configuration
30	0	00	error/reset register
33	1	01	Output(s) controlled by F0
34	2	02	Output(s) controlled by F0
35	4	04	Output(s) controlled by F1
36	8	08	Output(s) controlled by F2
37	16	10	Output(s) controlled by F3
38	4	04	not used
39	8	08	not used
40	16	10	not used
41	0	0	not used
42	0	0	not used
67	0	0	alt spd table step 1
68	0	0	alt spd table step 2
69	0	0	alt spd table step 3

CV	Default value		Description
	decimal	hex	
70	0	0	alt spd table step 4
71	0	0	alt spd table step 5
72	0	0	alt spd table step 6
73	0	0	alt spd table step 7
74	0	0	alt spd table step 8
75	0	0	alt spd table step 9
76	0	0	alt spd table step 10
77	0	0	alt spd table step 11
78	0	0	alt spd table step 12
79	0	0	alt spd table step 13
80	0	0	alt spd table step 14
81	0	0	alt spd table step 15
82	0	0	alt spd table step 16
83	0	0	alt spd table step 17
84	0	0	alt spd table step 18
85	0	0	alt spd table step 19
86	0	0	alt spd table step 20
87	0	0	alt spd table step 21
88	0	0	alt spd table step 22
89	0	0	alt spd table step 23
90	0	0	alt spd table step 24
91	0	0	alt spd table step 25
92	0	0	alt spd table step 26
93	0	0	alt spd table step 27
94	0	0	alt spd table step 28
95	0	0	reverse trim
116	0	0	torque kick rate
117	0	0	torque kick strength
118	20	14	ditch light hold time
120	1	01	output 1 EFX generator
121	2	02	output 2 EFX generator
122	0	00	output 3 EFX generator
123	0	00	output 4 EFX generator

## Description of function mapping CVs:

Function mapping can change which outputs are controlled by a function command from your handheld cab. It is possible to have one command control several outputs. In the table below each row corresponds to a function mapping CV and each column indicates an output number. The **bold** number in a column is the factory default. Programming the CV to the value under an output number will change that output to be controlled by that function number. In the table below the factory value of CV35 is 4 which means F1 will control Output #3. If you want F1 to control output 4 program CV35 to 8. If you want F1 to control both outputs 3 and 4 add the two values for those outputs together (4+8=12) and program CV35 with 12.

Note in this decoder CV33 and CV34 operate identically. They are not directional...directionality is provided in the EFX configuration CV for each output.

Factory default function mapping values

	OUTPUT NUMBER			
	4	3	2	1
CV33 F0 Fwd	8	4	2	<b>1</b>
CV34 F0 Rev	8	4	<b>2</b>	1
CV35 F1	8	<b>4</b>	2	1
CV36 F2	<b>8</b>	4	2	1
CV37 F3	8	4	2	1
CV38 F4	1			
CV39 F5	1			
CV40 F6	1			

## Configuration of CV29 settings:

Table of commonly used values for CV29

Value for CV29	Long/Short	Uploadable/Factory	Analog	14 or 28 Speed
decimal	hex	Address	Conversion	mode
2	2	Short	Factory	no
6	6	Short	Factory	yes
18	12	Short	Uploadable	no
22	16	Short	Uploadable	yes
34	22	Long	Factory	no
36	24	Long	Factory	yes
38	26	Long	Factory	yes
48	30	Long	Uploadable	no
50	32	Long	Uploadable	no
52	32	Long	Uploadable	yes
54	36	Long	Uploadable	yes

Note: If you want the locomotive to operate in the opposite direction increase the indicated value for CV29 by one. (Hex numbers are provided for Digitrax users)

## Recommend dropping resistors if using 1.5 volt bulbs

Bulb Current	Track Voltage								Wattage
	12.5	13	13.5	14	14.5	15	15.5	16	
15ma	680	680	720	750	820	820	910	910	¼ watt
30ma	330	360	360	390	390	430	430	470	½ watt
40ma	240	270	270	300	300	300	330	330	1 watt
50ma	200	200	220	220	240	240	270	270	1 watt
60ma	160	180	180	200	200	200	220	220	1 watt
80ma	120	130	130	150	150	160	160	160	2 watt

## Fine tuning locomotive operation

The factory settings normally provide good performance for most locomotives in HO-Scale. You may want to improve or fine tune performance by adjust the starting characteristics or top speed. There are 6 CVs that define:

- The voltage at which the motor starts
- How often and how hard the motor gets kicked a slow speeds to keep it turning smoothly.
- The maximum motor speed
- The mid speed range response characteristics or 'speed curve'.
- Compensation for a motor that runs faster in one direction

### Start Voltage - CV2 (Vstart):

We prefer using Operations Mode Programming (Program on the Main) to set CV2 so the locomotive is **just able** to maintain movement at speed step 1. You can also use the programming track... it just takes a bit longer to find the right setting for CV2.

### Torque compensation kick rate - CV116:

How frequently the motor is 'kicked' at slow speed. Typical adjustment is 2 to 4. The smaller the number the more often the motor gets a brief voltage 'kick'. Factory default is 0 (off). A value of 1 applies kicks continuously. The maximum practical value is about 8.

### Torque compensation kick strength - CV117:

How hard the motor is 'kicked' at slow speed. Typical adjustment is 4 to 25. The larger the number the more voltage is applied in each 'kick'. The strength of these kicks fade out ratiometrically as speed is increased providing a smooth transition to normal motor operation. Factory default is 0 (off), usable range 0-50.

### Vmax - CV5:

If your locomotive runs too fast you can use CV5 to lower its maximum speed. Setting CV5 to 255 uses the maximum possible voltage to run the motor when full speed is requested. Set CV5 to a smaller value to reduce the top speed. A value of 128 will yield approximately ½ full voltage to the motor at top speed. 192 will provide about ¾ full voltage. All speeds from the middle speed step to the maximum will be proportionally reduced (see diagram). If CV5 is set to 0 the decoder will use 255 for maximum speed. Always make sure CV5 is greater than CV6 to avoid erratic operation.

Vmid - CV6: CV6 determines how the motor responds through its middle speed ranges to advancement of the throttle. If you set CV6 lower than half the maximum speed you'll have smaller increases in motor speed through the lower speed ranges. Then, as you hit the upper speed ranges there will be larger increases between speed steps. In the diagram below you can see this best illustrated by the factory default line. If you set Vstart larger than 0 you'll most likely want to raise Vmid so a reasonable slope is maintained in the 'speed curve'. If CV6 is set to 0 the decoder will use 127 as the value. If you use high values in CV57 you will want to increase CV6 by proportional amount to keep a smooth acceleration curve.

### Reverse trim (also forward trim) - CV95:

Values from 1-127 make decoder run **faster in reverse** than forward. 1 is one speed step faster in reverse, 2 is two steps faster, etc.

Values from 129-255 make decoder run **faster in forward** than reverse. 129 is one speed step faster in forward, 130 is 2 speed steps faster, etc. 0 and 128 add nothing to either direction.

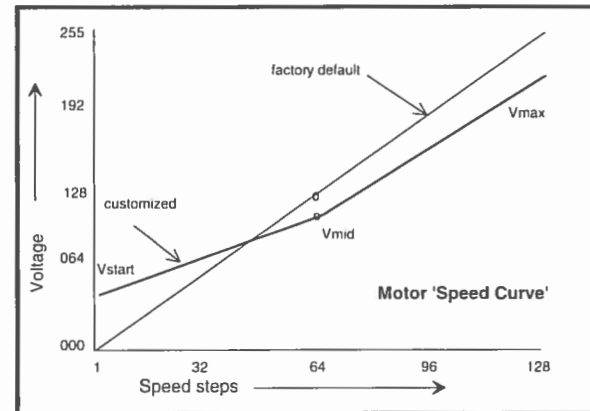

## Function mapping and effects programming examples

### Ditch lights:

What we want to do:

- Use outputs 2 and 3 (yellow and green wires) for the left and right ditch lights
- They will be controlled by F2 which is the HORN button on most DCC systems
- They should continue flashing for 5 seconds after the HORN button is released

How to do it:

- ✓ Program outputs 3 and 4 to both be activated by F2. Set the F2 mapping CV (CV36) to 12. We get the value of 12 by adding the values for output 3 and output 4 on the F2 line of the CV mapping table on page 6.
- ✓ Program outputs 3 and 4 for ditch light operation. Set CV122 to 56 and CV123 to 60. Using these values the lights will be 'qualified' by the headlight AND function 2. The headlight must be on for the ditch lights to be activated by F2. Type 1 ditch lights are on constantly on when the headlight is on and alternately flash when the horn is blown. Type 2 ditch lights are normally off until the horn is blown. This example is for the more common Type 1. If you prefer Type 2 use EFX values 52 and 48 instead of 60 and 56.
- ✓ CV118 sets the amount of time the ditch lights stay flashing after the horn (F2) is deactivated. The time is measured in 1/4 second intervals, for a hold time of 5 seconds put a value of 20 in the CV118.
- ✓ One last thing: Set CV35 to 0 so output 3 is not also controlled by F1

### Mars Light:

What we want to do:

- ➔ Use output 3 (marked A on decoder) for a Mars light.
- ➔ It is to be on in the forward direction only

How to do it:

- ✓ Output 3 is already activated by F1 (factory default setting of CV35=4).
- ✓ Configure output 3 as a forward only Mars light. Set CV122 to 9. We get the value of 9 by using 8 (Mars Light) plus 1 (output operates only in forward direction)

### Rule 17 lighting:

Rule 17 refers to how the locomotive engineer operates the locomotive headlights during the running of the train. The rule varies from road to road but generally requires the dimming of the headlight(s) when in a siding waiting to meet another train, passing through passenger stations or moving within yard limits.

What we want to do:

- ➔ Use output 1 for the Headlight
- ➔ The headlight is to be on bright in both directions of locomotive travel
- ➔ We also want to be able dim the headlight
- ➔ Use output 2 for the rear light. It is to come on in reverse, off in forward

How to do it:

- ✓ Output 1 is already activated by F0 (factory default setting of CV33 =1).
- ✓ Configure output 1 as a standard output, on in both directions, yet dimmable when F4 is activated. Set CV120 to 32 (20 hex). You can optionally set CV120 to 36 if you want F8 to control the dimming instead of F4.
- ✓ Configure the rear light to be on in reverse and off in forward operation: Set CV121 to 2

### Switcher:

What we want:

- ➔ Headlights that dim in the opposite direction that the locomotive is travelling
- ➔ Use output 1 as Headlight and output 2 as Rearlight

How to do it:

- ✓ Outputs 1 and 2 are already activated by F0 due to the factory default settings.
- ✓ Configure output 1 as bright in forward dim in reverse. Set CV120 to 44 (2C hex)
- ✓ Configure output 2 as bright in reverse dim in forward. Set CV121 to 40 (28 hex)

## Description of EFX configuration CVs

- CV120 - Lighting effect configuration for output 1 (white wire).
- CV121 - Lighting effect configuration for output 2 (yellow wire).
- CV122 - Lighting effect configuration for output 3 (green wire).
- CV123 - Lighting effect configuration for output 4 (violet wire).

Each output wire can select from 15 different lighting effects by using its associated EFX configuration CV. Pick the value for the CV from the table below, add 1 or 2 if you want the effect to be directional (footnotes 2 and 3), then add 128 if you are using a white LED for the effect. Ditch lights should not be made directional, they're not directional in real life.

bit weight	128	64	32	16	8	4	2	1
bit name	LED <sup>1</sup>	---	Effect configuration				REV <sup>2</sup>	FWD <sup>3</sup>

Value for CV	Description of lighting effect	Hex (for Digitrax users)
0	Standard on/off function output	0
4	Firebox flicker (brighter when accelerating)	4
8	Mars light	8
12	Rotary Beacon	0C
16	Gyalight	10
20	Double Strobe	14
24	Strobe A	18
28	Strobe B (alternates with Strobe A)	1C
32	Dim when F0 and F4 on, otherwise bright	20
36	Dim when F0 and F8 on, otherwise bright	24
40	Dim in forward, bright in reverse	28
44	Dim in reverse, bright in forward	2C
48	Type 2 Right Ditch light, effect on if F2 on, output off otherwise	30
52	Type 2 Left Ditch light, effect on if F2 on, output off otherwise	34
56	Type 1 Right Ditch light, effect on if F0 and F2 on, bright if F0 on and F2 off, off if F0 off	38
60	Type 1 Left Ditch light, effect if F2 and F0 on, bright if F0 on and F2 off, off if F0 off	3C

1 - Functions are designed to use 12-16 volt 30-40ma incandescent lamps. If you are using a white LED (with 1K limiting resistor) add 128 to the CV value.

2 - If you want the function to be active only in the reverse direction add 2 to the CV value

3 - If you want the function to be active only in the forward direction add 1 to the CV value